

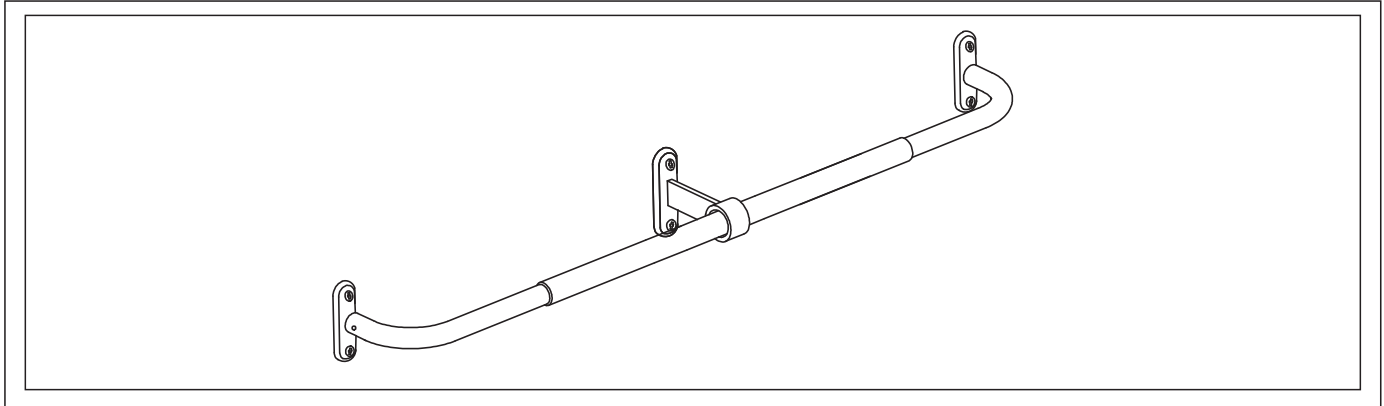



PRODUCT NAME: French Return Drapery Hardware

ITEM NUMBER: DH064, DH065, DH066

ASSEMBLED DIMENSIONS : 28"-48" x 3/4" Diameter
48"-88" x 3/4" Diameter
60"-108" x 3/4" Diameter

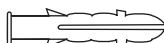
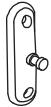
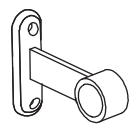
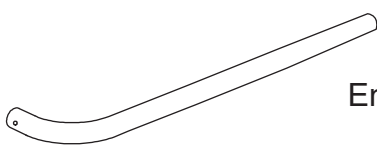
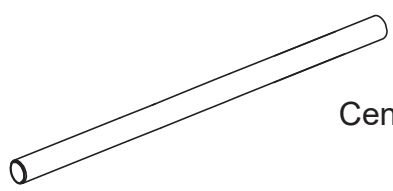

Ltr.	Qty.	Hardware & Components Included
A	6	 Mounting Screws
B	6	 Wall Anchors
C	2	 End Brackets (with Set Screw)
D	1	 Center Bracket (with Set Screw)
E	2	 End Rods
F	1	 Center Rod

REQUIRED TOOLS

Phillips Screwdriver
Level
Tape Measure
Pencil (or other marking tool)
*Electric Drill with 3/16" bit

Remove all parts, hardware and protective packaging from carton and carefully arrange on a clean, level, padded surface.

NOTE: To avoid accidentally discarding small parts or hardware, retain all carton contents until assembly and installation are complete.

*Drill and bit required for creating pilot hole for Wall Anchors (B).
Drill not used when mounting brackets into a wall stud.

STEP 1: Use a level and pencil to mark installation location for End Brackets (C) and Center Bracket (D).
NOTE: If a Bracket is centered on a Wall Stud drive Mounting Screw (A) directly in. If no stud, drill a small pilot hole and tap in Wall Anchor (B).

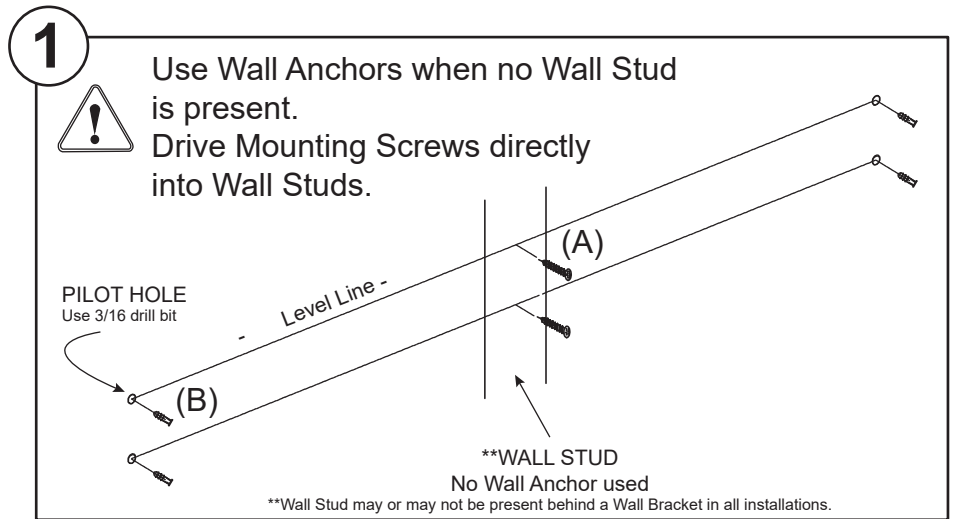

STEP 2: Place End Brackets (C) onto wall and drive in Mounting Screws (A). Fully tighten.
Place Center Bracket (D) onto Wall and drive in Mounting Screws (A). Fully tighten.

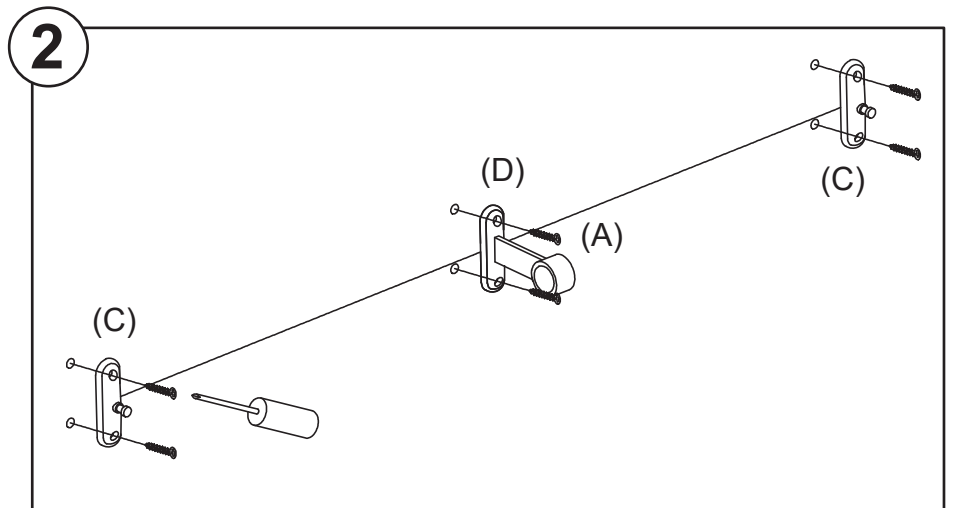

STEP 3: Slide Center Rod (F) into ring on end of Center Bracket (D). Next, slide straight end of one End Rod (E) into Center Rod. Fit curved end over End Bracket (C) then insert and tighten Set Screw. Repeat for remaining side.

IMPORTANT: Rings must be installed onto Rod(s) BEFORE attaching and installing Set Screw. (See inset)

RINGS NOT INCLUDED

