



**BALLARD  
DESIGNS**

***CANE-BACK DAYBED***







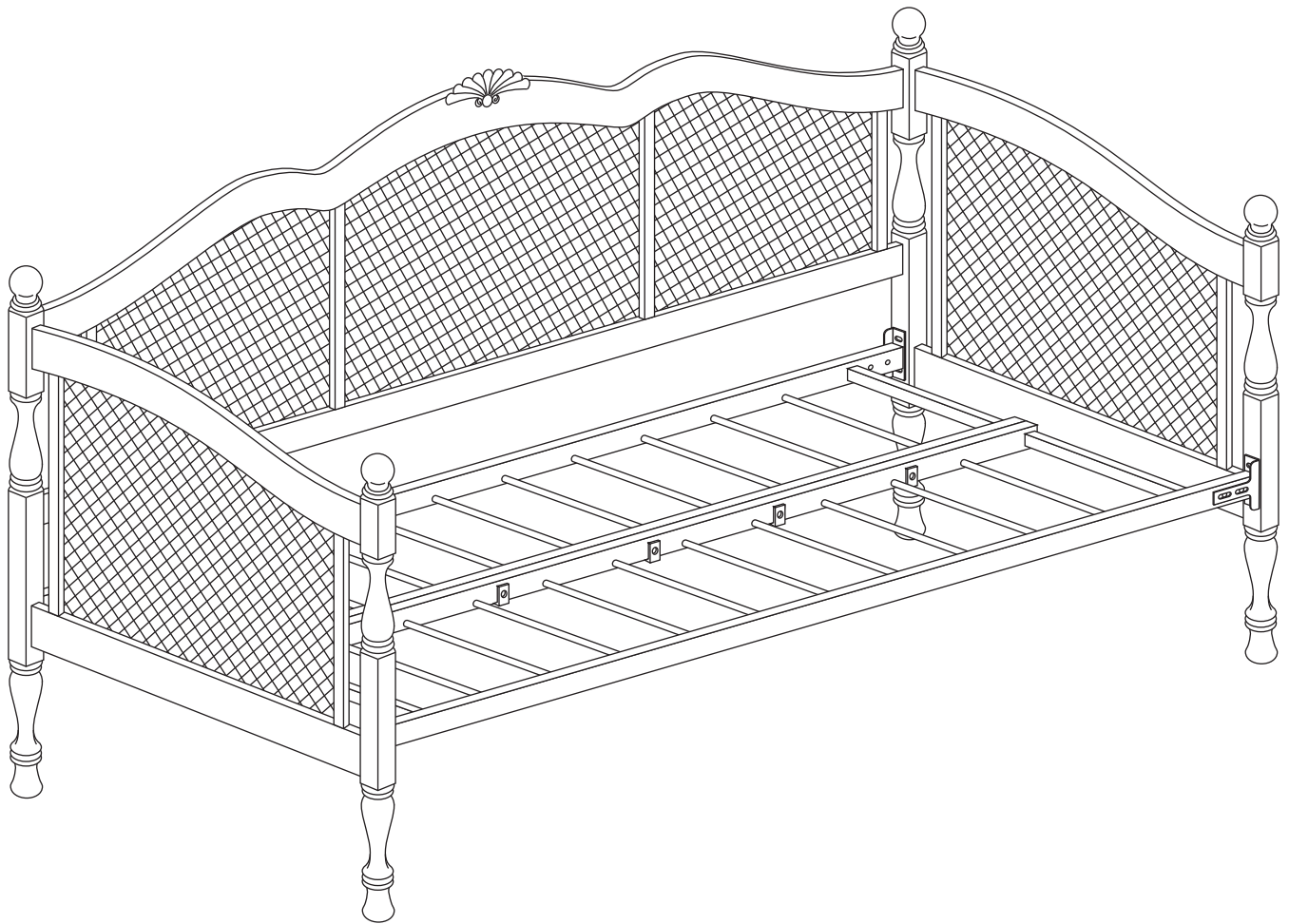

*Model #MB091 WWH*

*Model #MB091 WOO*

*Model #MB091 GRN*



**MADE IN CHINA**

No.	QTY	HARDWARE LIST
D	4	
E	12	
F	2	
G	4	
K	1	
J	8	
H	8	
I	8	
L	4	





**PARTS LIST**

- A (1) Back Panel
- B (1) Right Side
- C (1) Left Side

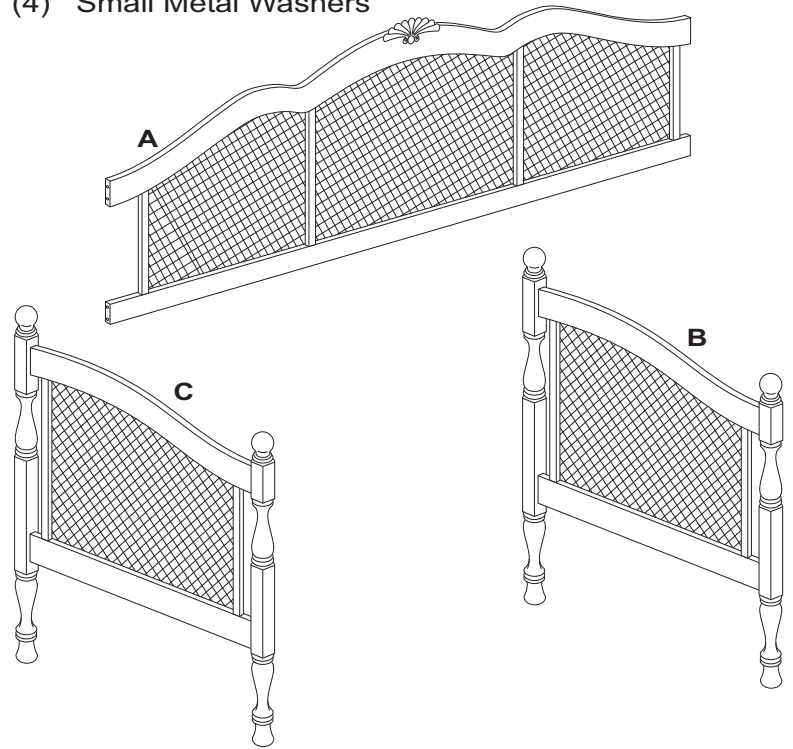
**HARDWARE LIST**

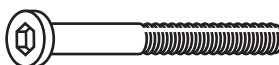
- D (4) Long Allen Bolts
- E (12) Spring Washers
- F (2) Wood Dowels
- G (4) Wood Plugs
- H (1) Allen Wrench
- I (8) Rubber Washers
- J (8) Short Allen Bolts
- K (8) Large Metal Washers
- L (4) Small Metal Washers

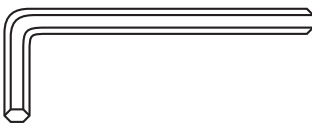

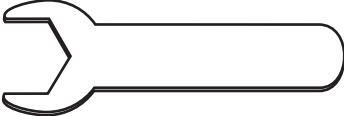
No.	QTY	HARDWARE LIST
A	4	
B	4	
C	1	
D	8	
E	8	
F	1	

**SUSPENSION DECK  
HARDWARE LIST**

- A (5) Allen Bolts M6 x 56mm
- B (8) Allen Bolts M6 x 30mm
- C (1) Allen Wrench
- D (13) Hex Nuts
- E (26) Flat Washers
- F (1) Hex Wrench

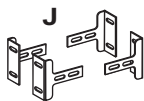

**PARTS LIST**

- G (2) Bed Frames
- H (5) Connectors
- J (4) Frame Plates

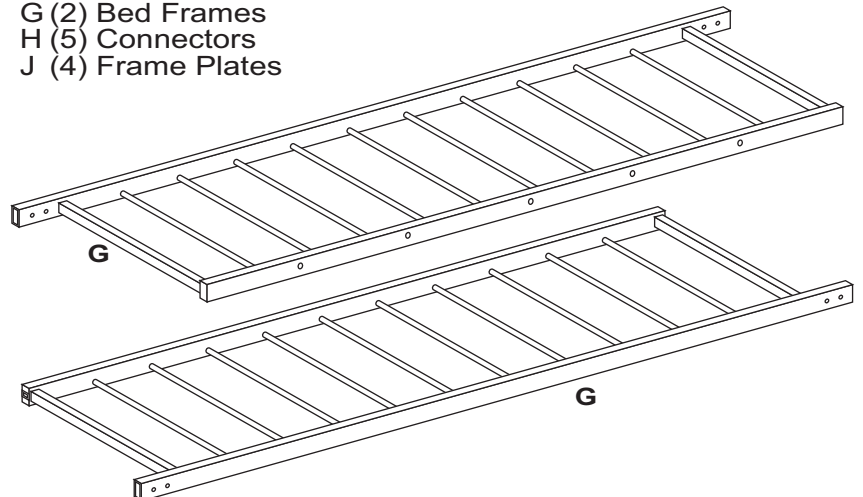

Parts Bag Located Here

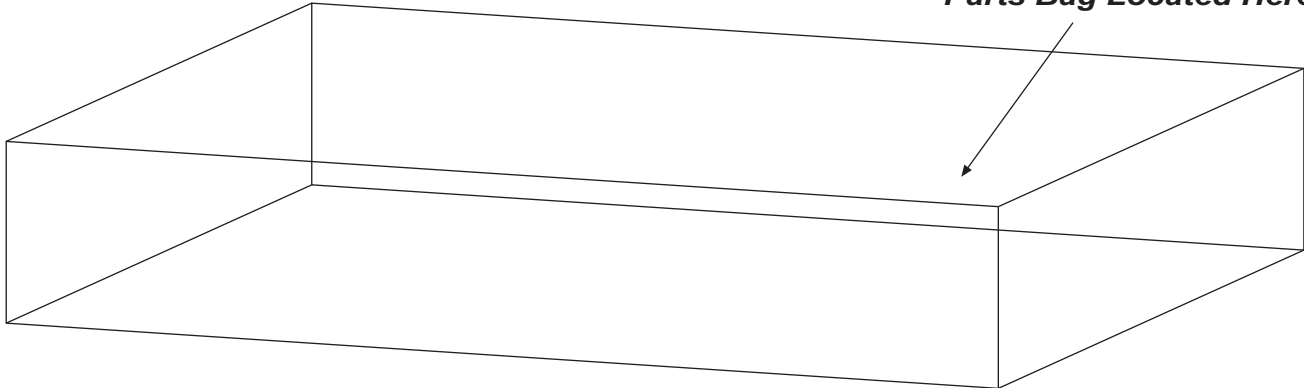

**SUSPENSION DECK**

Model #90008 Metal Frame

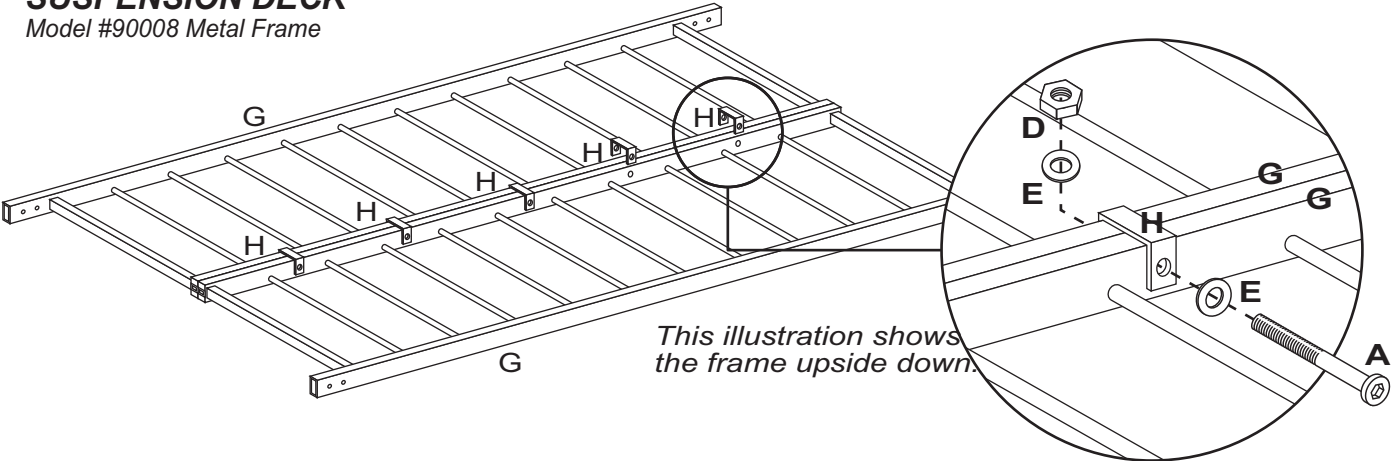

*This illustration shows the frame upside down.*

**STEP 1**

Begin assembly by attaching each Bed Frame (G) together by aligning the holes and securing with the 5 Connectors (H). Fit together and secure in place with 1 Allen Bolt (A), 1 Flat Washer (E), on the other side 1 Flat Washer (E) & 1 Hex Nut (D). Tighten all bolts and nuts using the Allen and Hex Wrenches (C & F) that have been provided.

**STEP 2**

Attach each Frame Plate (J) to the end of each Bed Frame (G) by aligning holes and securing with 2 Allen Bolts (B), 2 Flat Washers (E), on the other side 2 Flat Washers (E) & 2 Hex Nuts (D). Do not fully tighten bolts and nuts until the Suspension Deck has been assembled to the daybed.

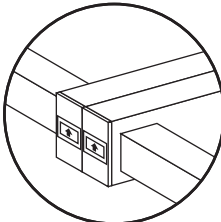
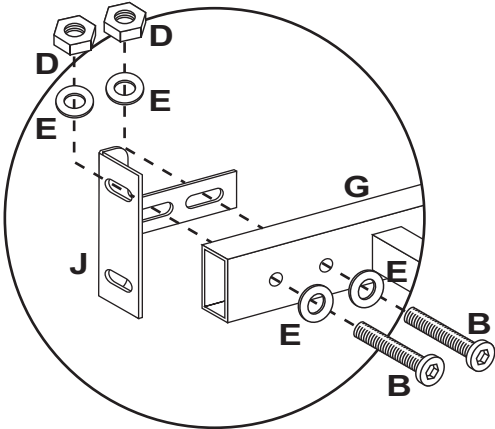

**This Side Up**

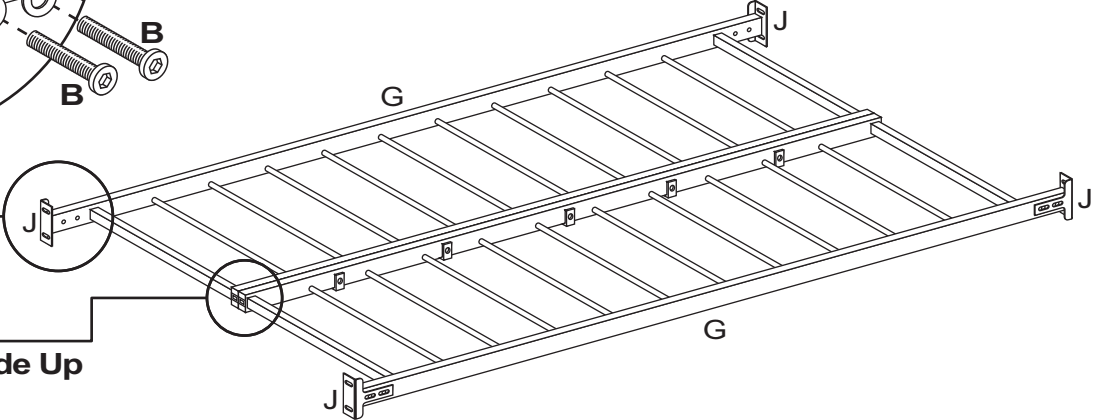



**STEP 1**

Begin assembly, by first attaching both Right & Left Side panels (B & C) to the Back Panel (A), by inserting each Wood Dowel (F) in place and guiding the panels together, securing with 2 Long Allen Bolts (D), 2 Spring Washers (E) & 2 Small Metal Washers (L) per each side. Do not fully tighten bolts for this step.

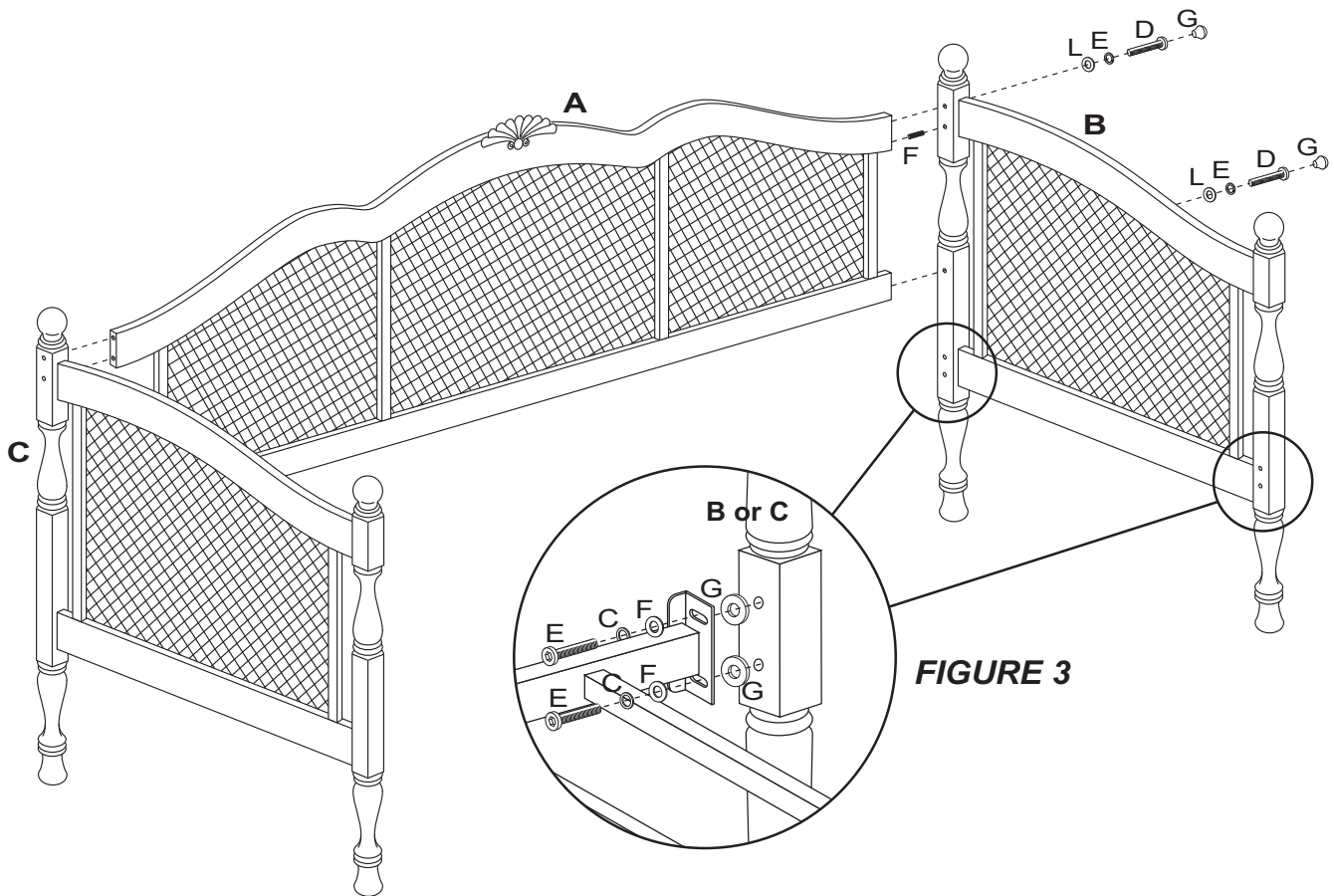

**STEP 2**

Attach the Suspension Deck (Now Assembled) to each post on Side Panel (B & C), using 2 Short Allen Bolts (E), 2 Spring Washers (C), 2 Large Metal Washers (F) & 2 Rubber Washers (G) per each post. See Figure 3.

**STEP 3**

Tighten all bolts and nuts from Page 3 using the hardware provided and carefully insert one Wood Plug (G) into each hole on the back post of each daybed side to cover Allen Bolt Heads (D) for a total of four times to complete the assembly.