

PRODUCT NAME: Tuscan Desk Return (Top, Cabinet, Leg)
ITEM NUMBER: MO255 (Includes MO251 & MO254)
ASSEMBLED DIMENSIONS : 30"H x 72"W x 36"D

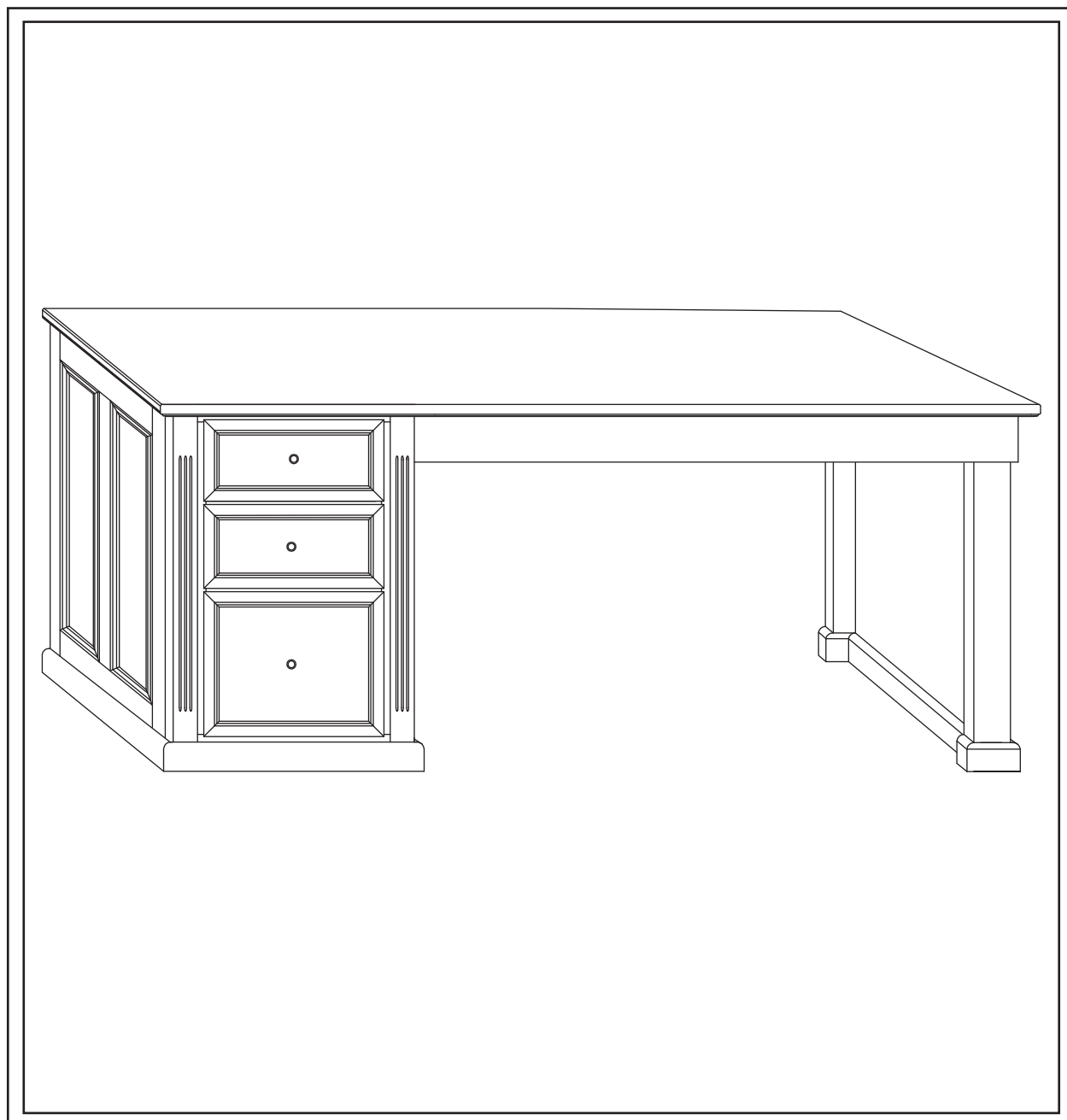

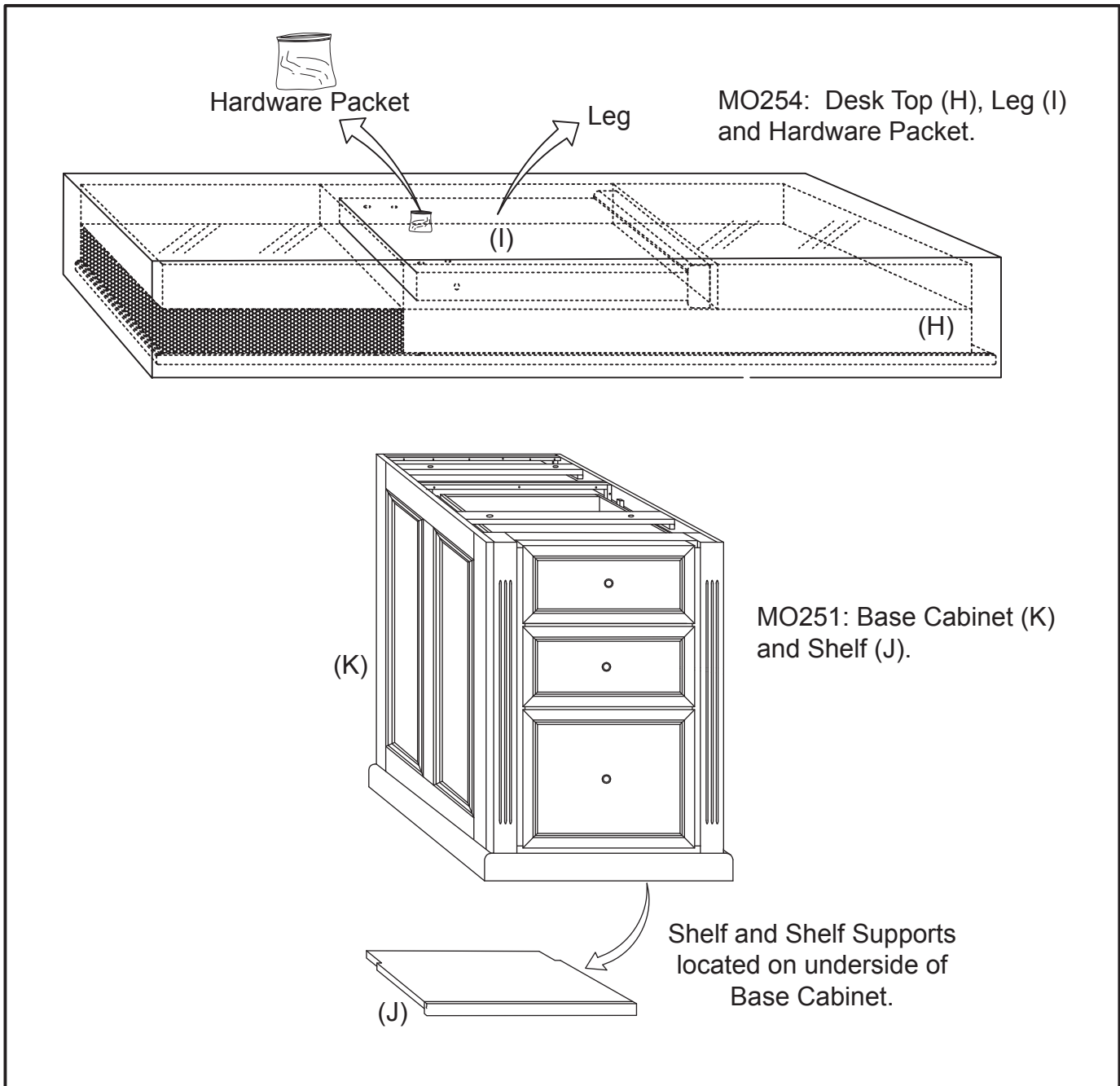





Return Desk comprised of two parts, MO254 Desk Top/Leg and MO251 Base Cabinet.
Illustration below shows location of parts and hardware.



NOTE

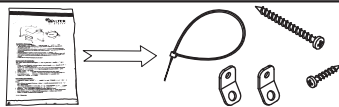

Carefully remove all outer packaging of both MO251 and MO254 and place components on a soft, level surface.

Ltr.	Qty.	Hardware Included
A	6	 Long Allen Bolt (A) 35mm to ATTACH LEG
B	4	 Short Allen Bolt (B) 29mm to ATTACH CABINET
C	10	 Lock Washer (C)
D	10	 Flat Washer (D)
E	1	 Allen Wrench (E)
F	4	 Shelf Support (F)
G	2	 Anti-Tip Kit (G)

TOOLS NEEDED:
 Allen Wrench (included)
 Screwdriver for Anti-Tip Hardware
 -Two person assembly suggested.

Remove all parts, hardware and protective packaging from carton and carefully arrange on a clean, level, padded surface.

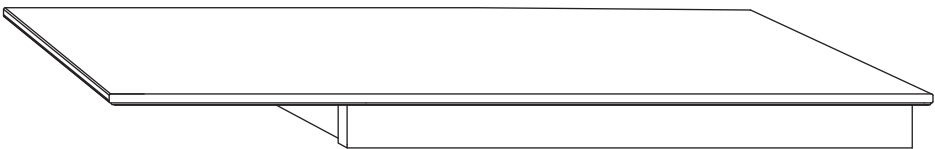
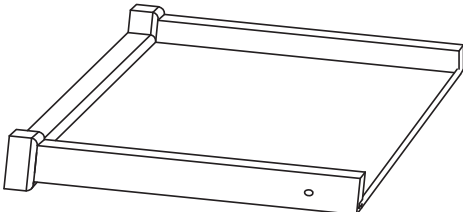
NOTE: To avoid accidentally discarding small parts or hardware, retain all carton contents until assembly and installation are complete.

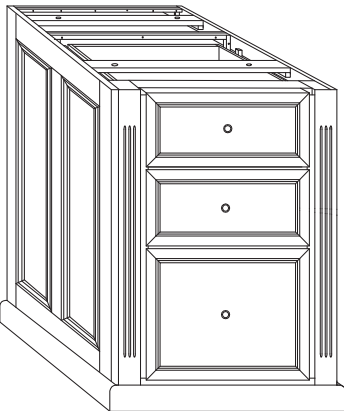
Ltr.	Qty.	Components
H	1	 Desk Top (H)
I	1	 Leg (I)
J	1	 Shelf (J)
K	1	 Base Cabinet (K)

NOTE: Assemble desk in location for intended use.

STEP 1: Orient Base Cabinet (K) in preferred direction and remove top drawer. Next, gently lower Desk Top (H) onto Base Cabinet and Leg (I). Place Leg on Apron end of Desk Top.

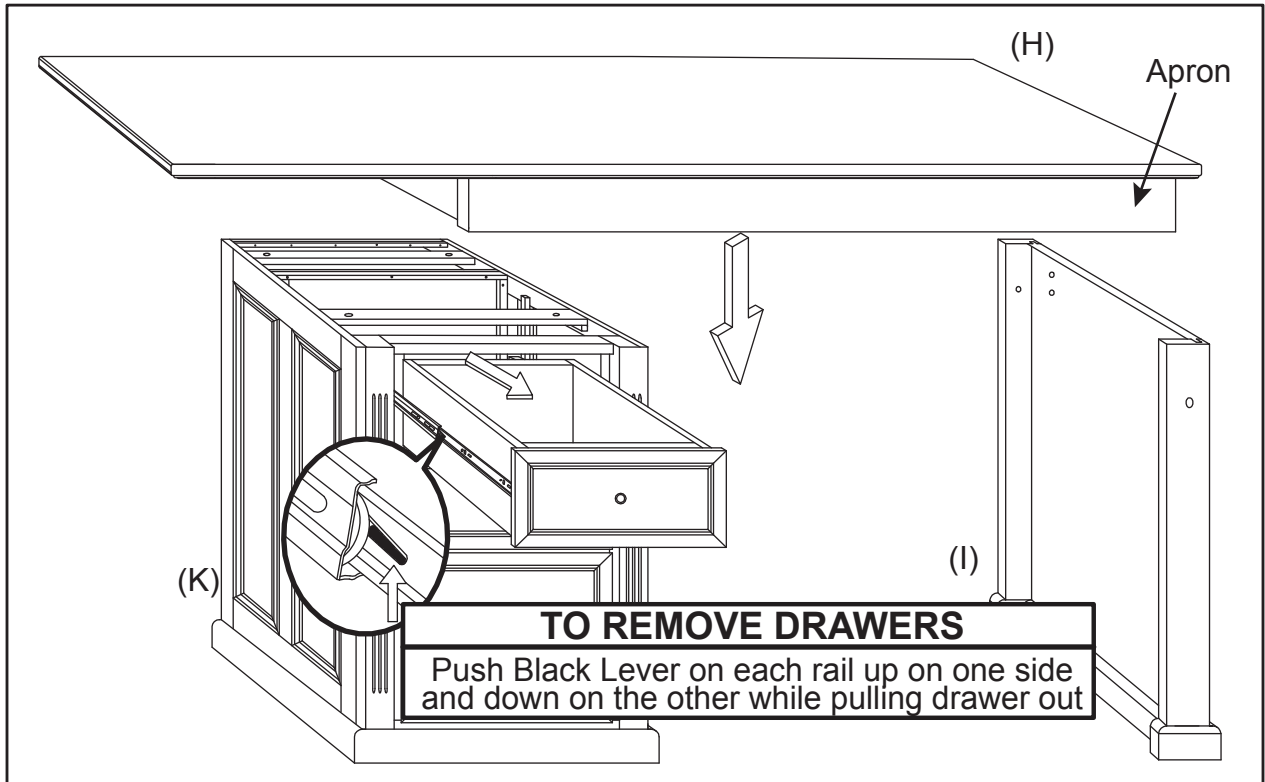

STEP 2: Assemble **Long** Allen Bolt (A), Lock Washer (C) and Flat Washer (D) and use to attach Leg (I). Assemble **Short** Allen Bolt (B), Lock Washer (C) and Flat Washer (D) and use to attach Base Cabinet (K) to Desk Top (H). Firmly tighten Bolts using Allen Wrench (E).

NOTE: To aid in placement, do not fully tighten Bolts until all are threaded into place.

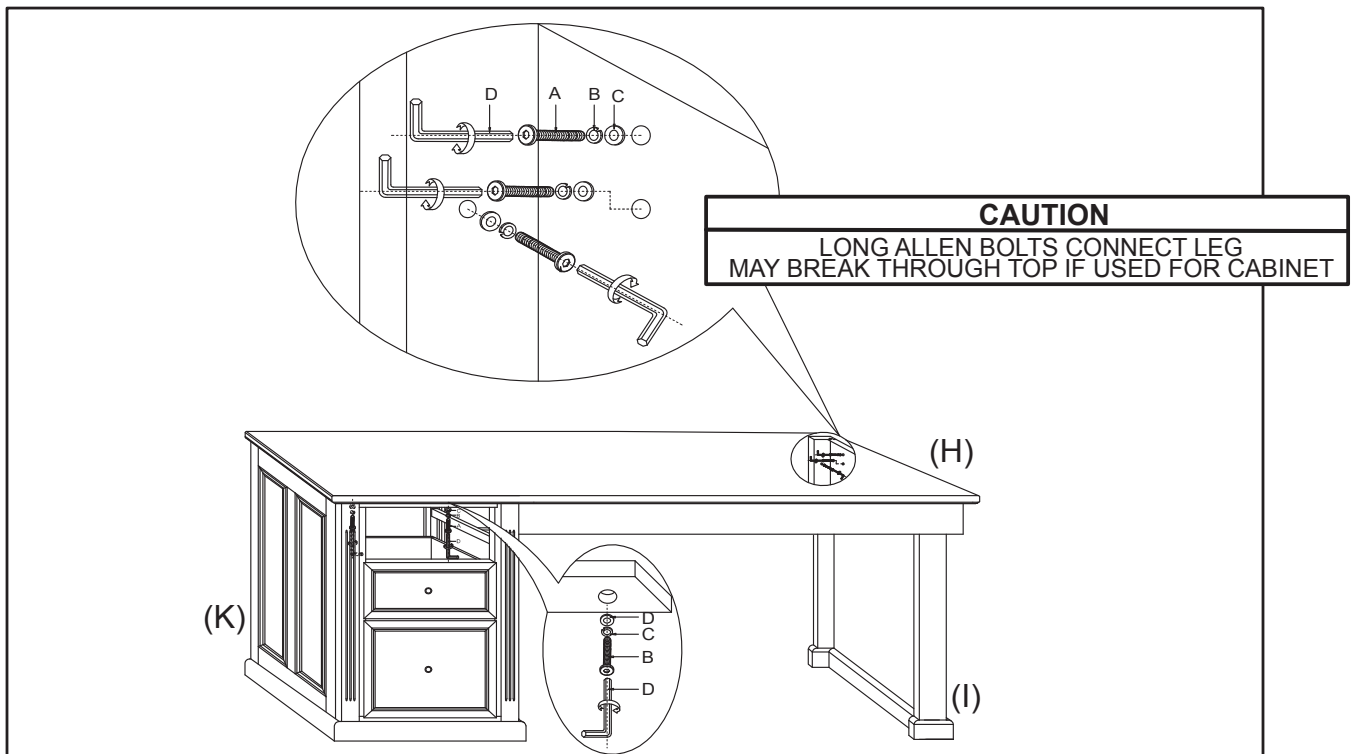

STEP 3: Gently insert Shelf Supports (F) into pre-drilled holes. Place Shelf (J) into Base Cabinet (K).

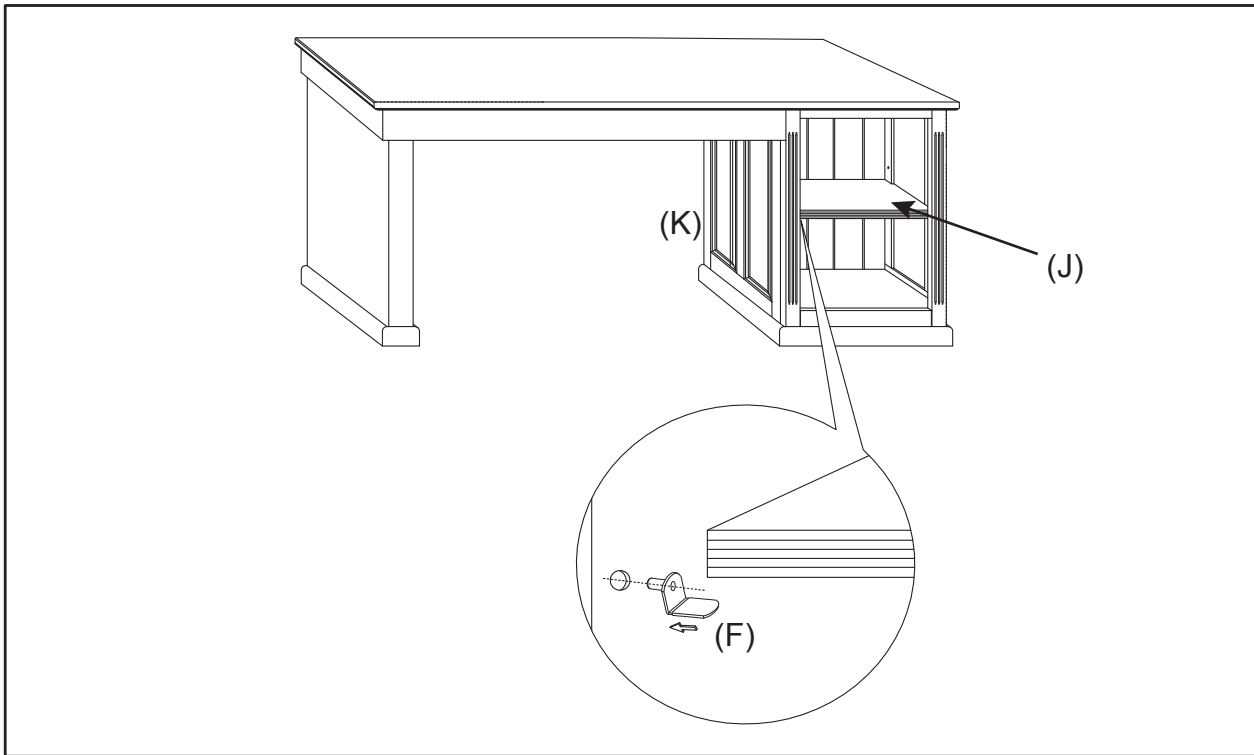



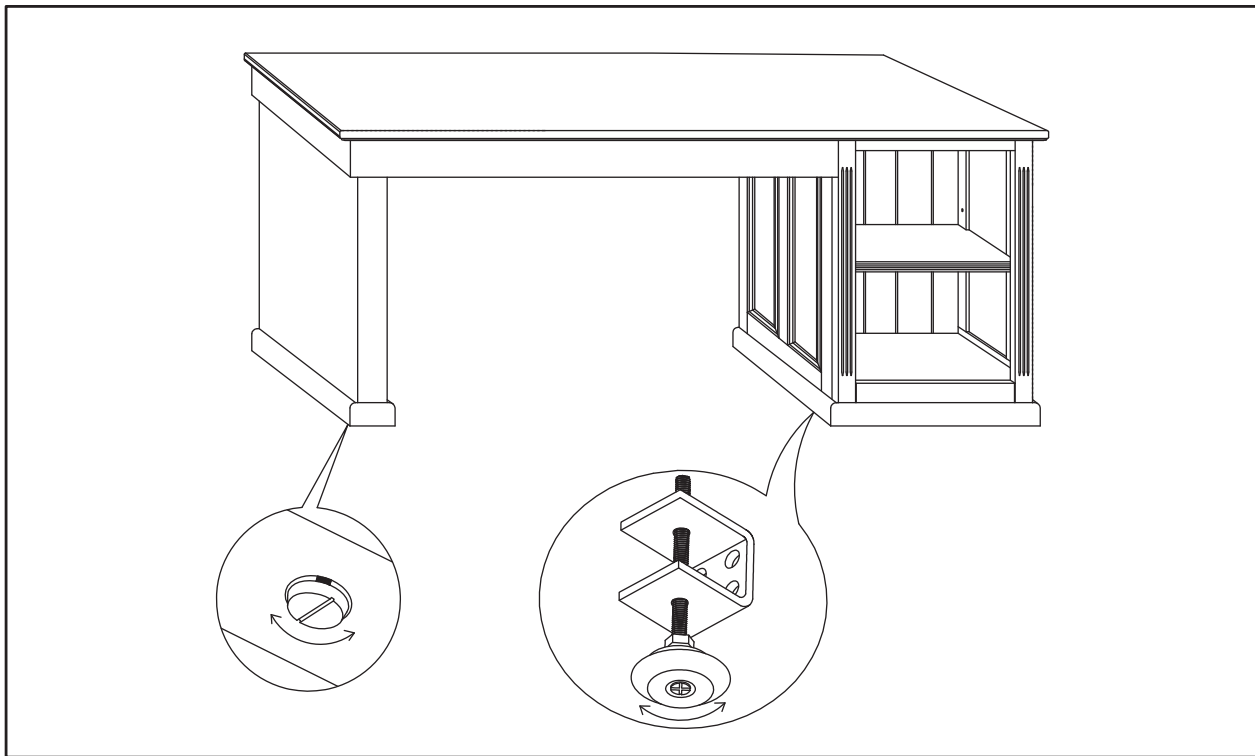

STEP 4: If necessary, desk may be leveled by adjusting Rotary Levelers located under each corner. Turn clockwise/counterclockwise until desk is level.



Cleaning & Care:

DO NOT use alcohol based products or spray polisher as finish damage may result.
Dust with a soft cloth.

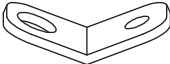
Anti Tip Installation Part C: Where applicable, attach desk to wall.

Ltr.	Qty.	Hardware Included	
A	2		Small Screw
B	2		Large Screw
C	4		Bracket
D	2		Retention Belt

Attach 2 Brackets (C) through the smaller holes to Desk with Small Screws (A)
 Attach remaining Brackets (C) **INTO A WALL STUD** with Large Screws (B) 2 inches below
 the Brackets attached to Desk. Align the Brackets vertically and
 string in the Retention Belts (D). Confirm Straps are securely laced and locked.

