

BALLARD DESIGNS®

Customer Service: 800-367-2810
Online: www.ballarddesigns.com

PRODUCT NAME: Verona Desk

ITEM NUMBER: MO444

ASSEMBLED DIMENSIONS : 30"H x 65"W x 29"D

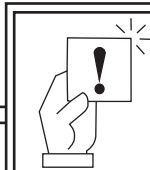
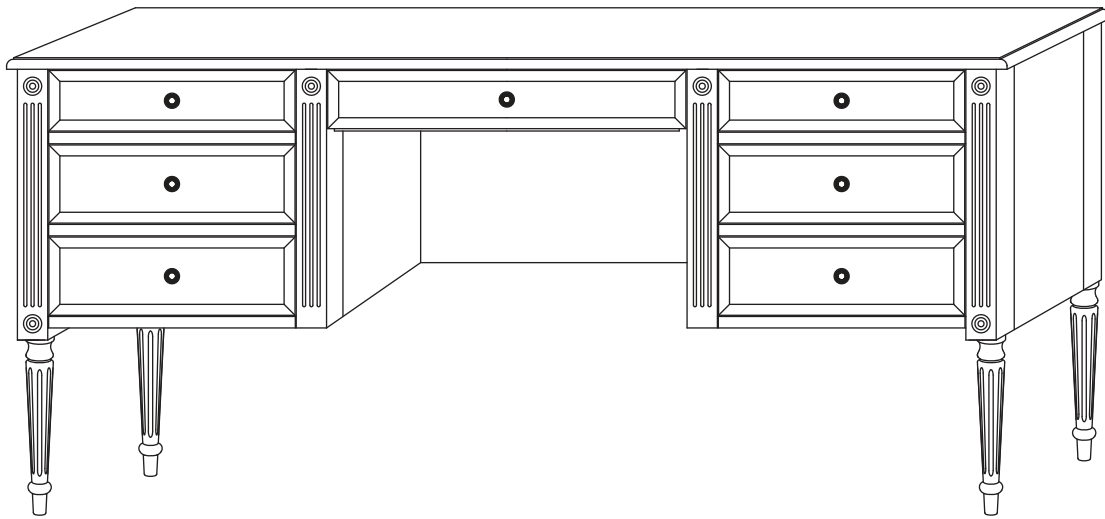

Prevent accidentally discarding small parts or hardware. Retain all carton contents until assembly and installation are complete.

PRODUCTS ARE NOT INTENDED
FOR COMMERCIAL USE.
UPDATED: 3-17-2023

MADE IN CHINA
Page 1 of 4

⚠ Assemble in location for intended use.

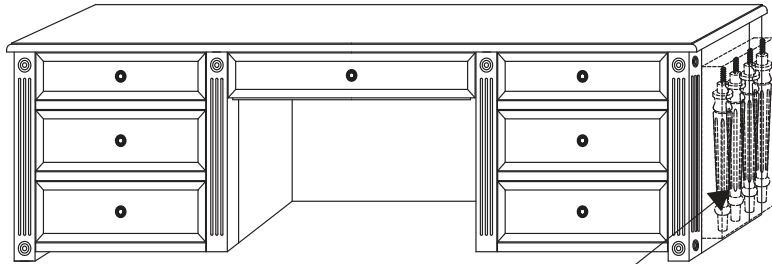



Legs (D) and File Bars (B)
Located here

NO TOOLS REQUIRED
-Two person assembly suggested.

Remove all parts, hardware and protective packaging from carton and carefully arrange on a clean, level, padded surface.

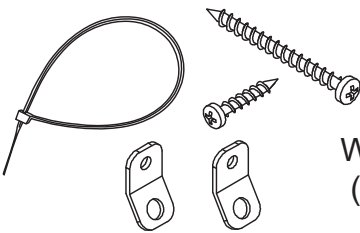
NOTE: To avoid accidentally discarding small parts or hardware, retain all carton contents until assembly and installation are complete.

Ltr.	Qty.	Hardware Included
A	2	 <p>Wall Anchoring (Anti-Tip) Kits See Page 4</p>
B	2	 <p>File Rods</p>

WARNING
Tip-Over Hazard
Prevent tipping accidents. Anchor your furniture.
ANCHORING HARDWARE INCLUDED

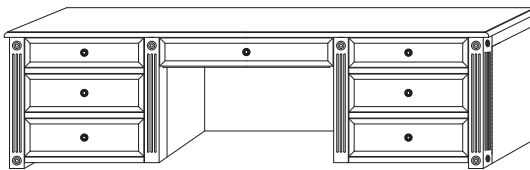
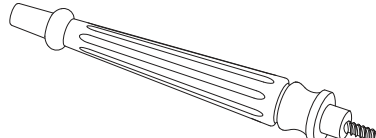
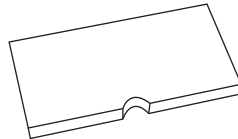
Ltr.	Qty.	Components
C	1	 <p>Desk (C)</p>
D	4	 <p>Legs (D)</p>
E	1	 <p>Cover (E)</p>

STEP 1: Carefully set Desk (C) onto its back onto a level, padded surface. Insert, turn and firmly tighten each Leg (D) as illustrated.

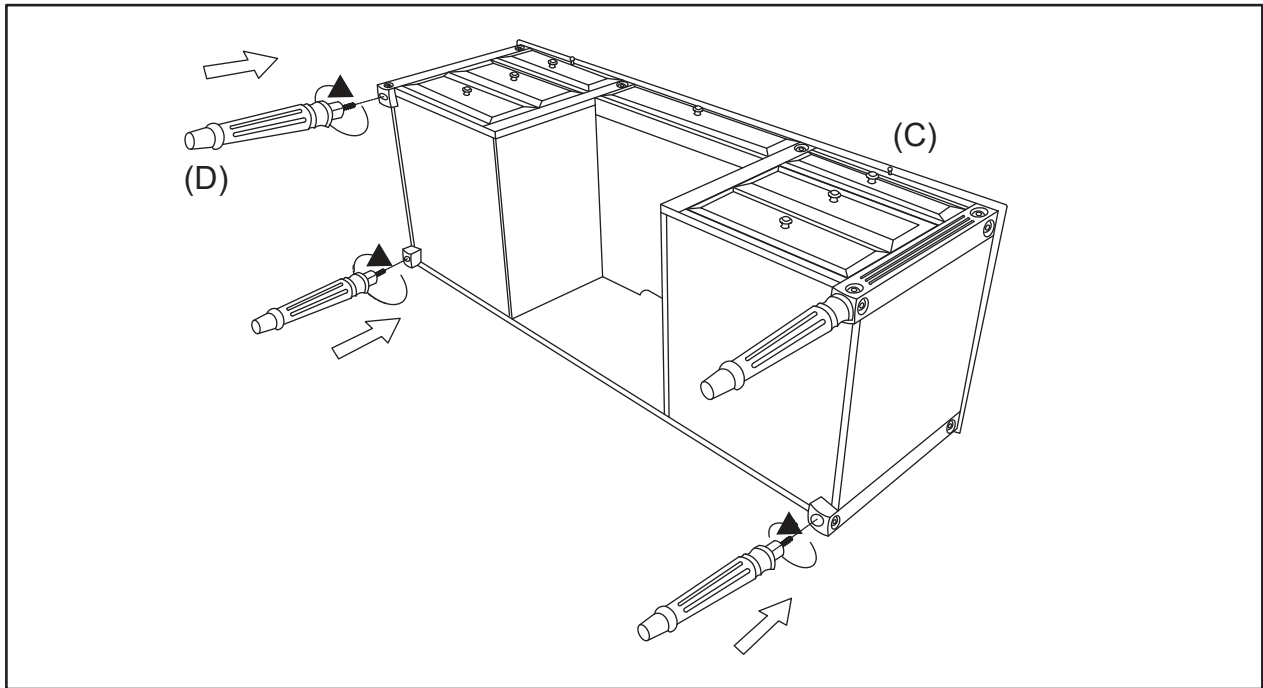

CAUTION: To avoid possible damage, do not place uneven pressure on Legs as you turn the desk upright.

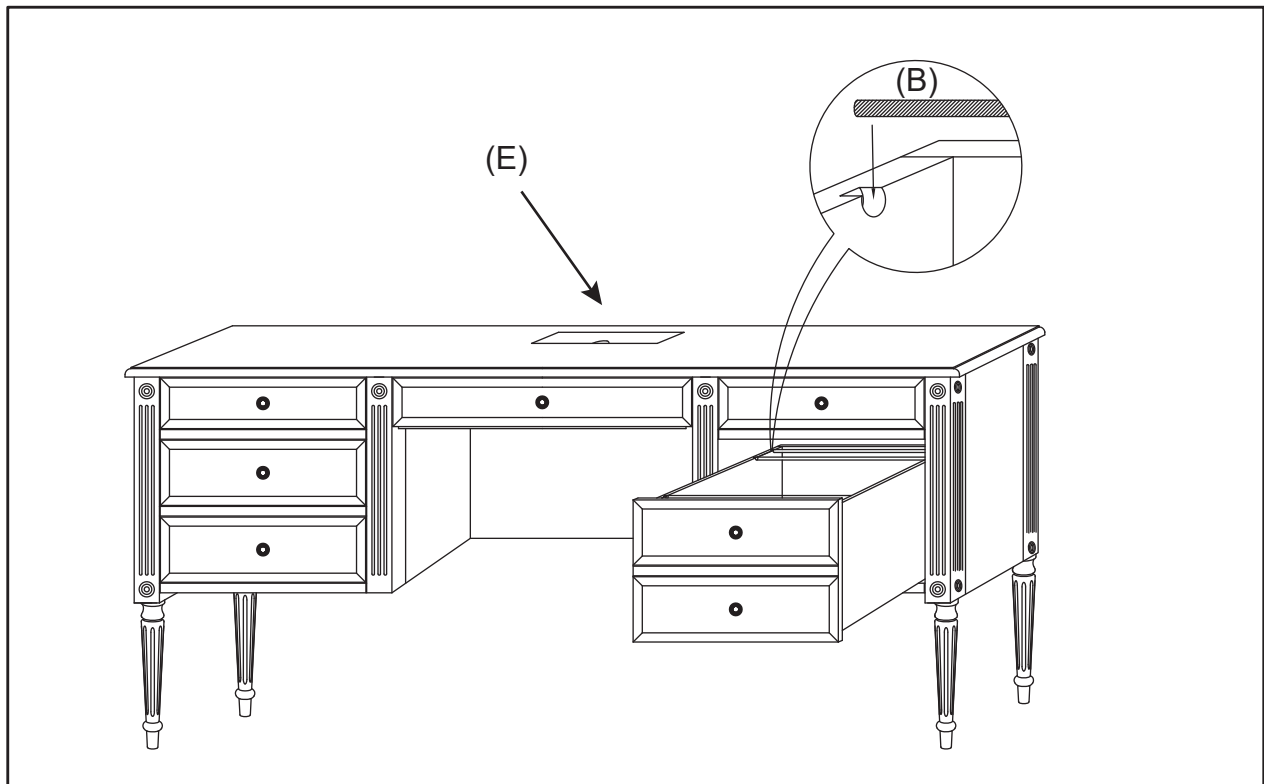

STEP 2: Place File Rods (B) into notches in sides of file drawer. Set Cover (E) into place as needed.

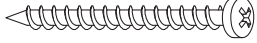
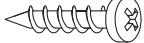
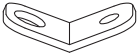

WALL ANCHORING HARDWARE (ANTI-TIP)

Ltr.	Qty.	Hardware Included	
A	2		Large Screw
B	2		Small Screw
C	4		Bracket
D	2		Retention Belt



Installation:

1. Place furniture against wall at desired location then locate and mark a Wall Stud behind unit.
2. Corresponding to Stud location, attach one Bracket (C) to back of unit using Small Screw (B).
3. To keep hardware out of view after installation, attach remaining Bracket (C) **INTO WALL STUD** with Large Screw (A) 2 inches below Bracket attached to back of unit.
4. Move unit into place, align Brackets then connect both using Retention Belt (D).
5. Confirm Belt is securely laced and locked.

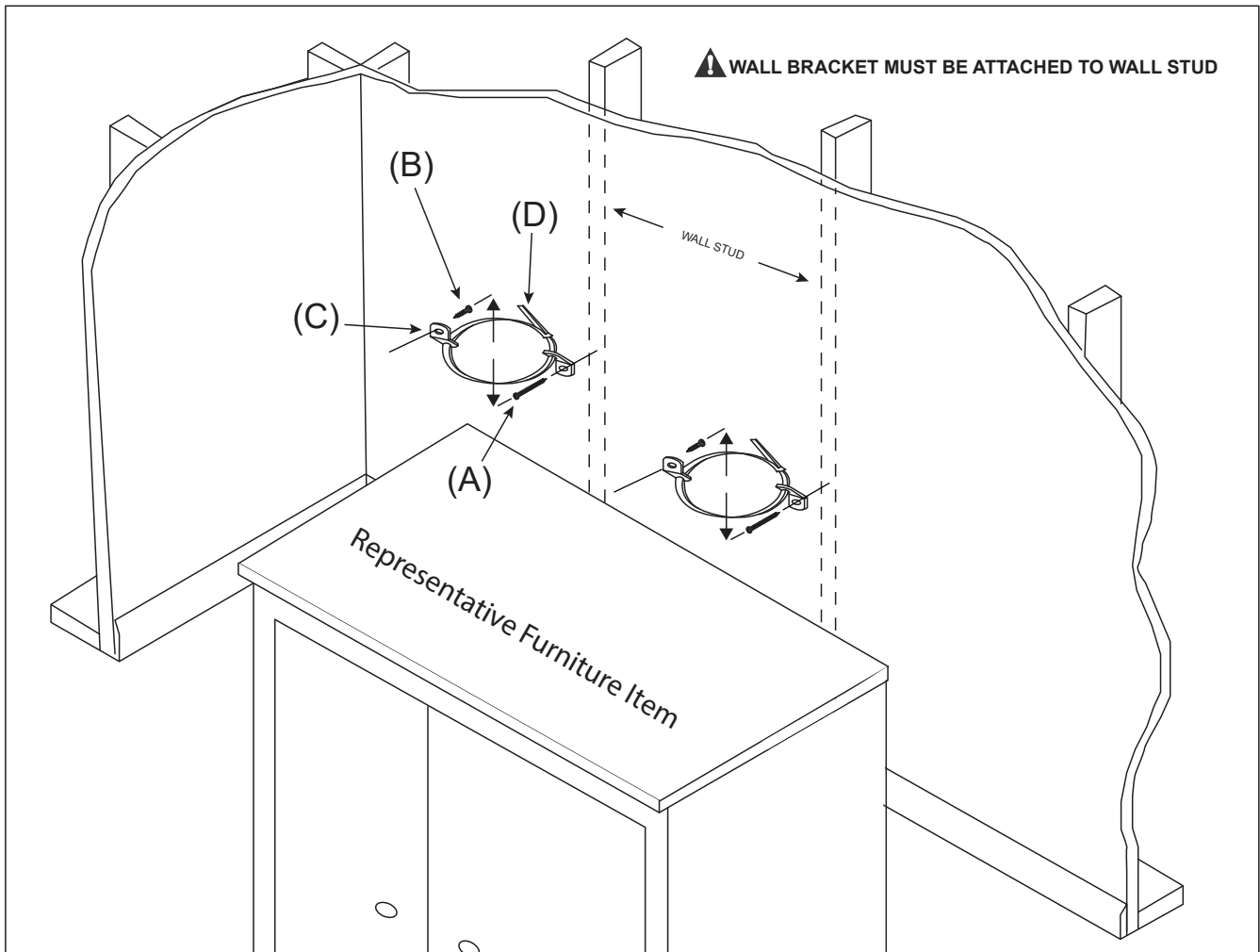

Cleaning & Care:

DO NOT use alcohol based products or spray polisher as they can damage the finish. Dust with soft cloth.