



PRODUCT NAME: Aman File Cabinet
ITEM NUMBER: MP005
ASSEMBLED DIMENSIONS : 33 5/8"H x 43 1/2"W x 20"D





WARNING
Tip-Over Hazard
ANCHORING HARDWARE INCLUDED

Serious or fatal crushing injuries can occur from a furniture tip-over
Prevent tipping accidents. Anchor your furniture.

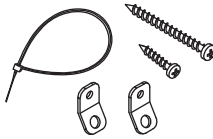

REQUIRED TOOLS:
Phillips Screwdriver

Ltr.	Qty.	Hardware/Components Included
A	2	 <p style="text-align: right;">Wall Anchoring (Anti-tip) Kit See page 2</p>
B	1	 <p style="text-align: right;">File Cabinet with 8 removable filing rods/rails</p>

File Rods/Rails: 8 rods are included and ship packaged on top inside of carton. To install, simply set rod ends into notches inside drawer. Designed to be configured for either Letter or Legal size file folders.

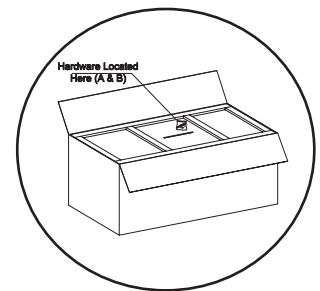
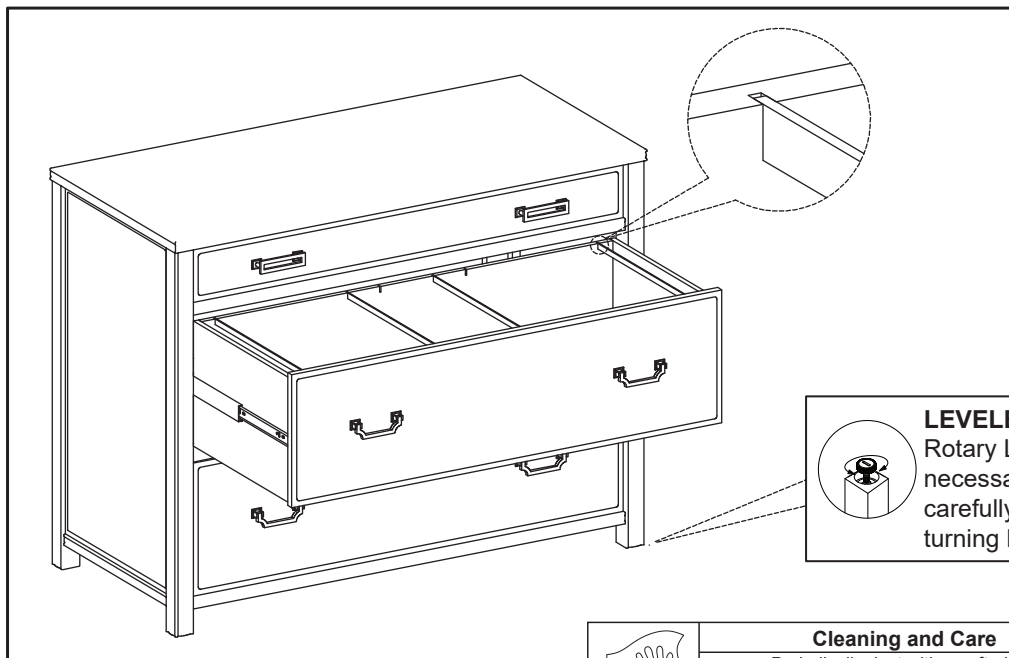







LEVELERS: Cabinet is equipped with Rotary Levelers installed under each leg. If necessary, adjustments may be made by carefully lifting applicable corner and turning Leveler clockwise/counterclockwise.



Cleaning and Care

Periodically dust with a soft, dry cloth.
Protect surfaces to prevent damage.
Do not use alcohol based cleaners or polishes.

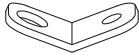
WALL ANCHORING HARDWARE (ANTI-TIP)

Ltr.	Qty.	Hardware Included	
A	2		Large Screw
B	2		Small Screw
C	4		Bracket
D	2		Retention Belt



Installation:

1. Place furniture against wall at desired location then locate and mark a Wall Stud behind unit.
2. Corresponding to Stud location, attach one Bracket (C) to back of unit using Small Screw (B).
3. To keep hardware out of view after installation, attach remaining Bracket (C) **INTO WALL STUD** with Large Screw (A) 2 inches below Bracket attached to back of unit.
4. Move unit into place, align Brackets then connect both using Retention Belt (D).
5. Confirm Belt is securely laced and locked.

