





PRODUCT NAME: Verona 2 Drawer File Cabinet
ITEM NUMBER: MP010
ASSEMBLED DIMENSIONS : 30"H x 20.6"W x 20"D

REQUIRED TOOLS:

Phillips Screwdriver

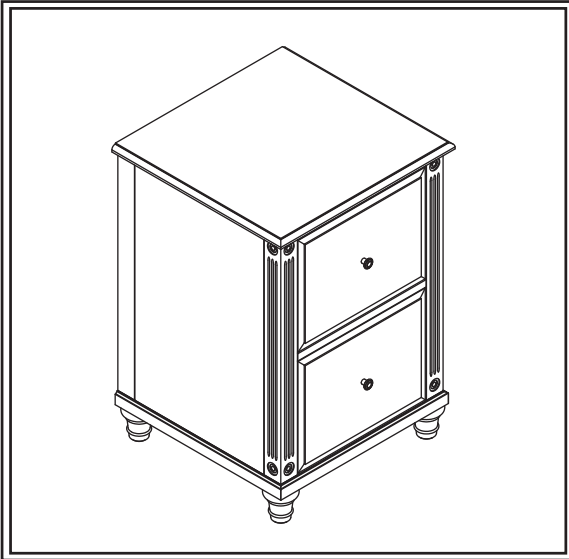
ASSEMBLY TIME: 15 minutes

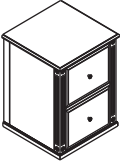

Ltr.	Qty.	Hardware/Components Included
A	2	 Wall Anchoring (Anti-tip) Kit See page 2
B	4	 Feet
C	1	 Cabinet

ASSEMBLY: Place Cabinet (C) back down onto a padded, level surface. Insert, turn and tighten Feet (B) into embedded T-nuts in each corner.

LEVELERS: Each Foot (B) is equipped with a Rotary Levelers. To adjust, lift applicable corner and turn Leveler clockwise/counter-clockwise.

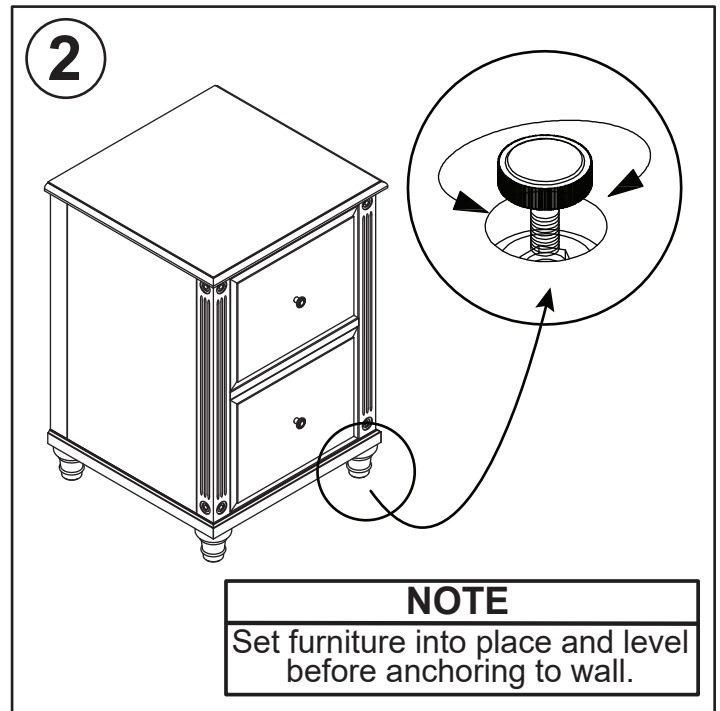
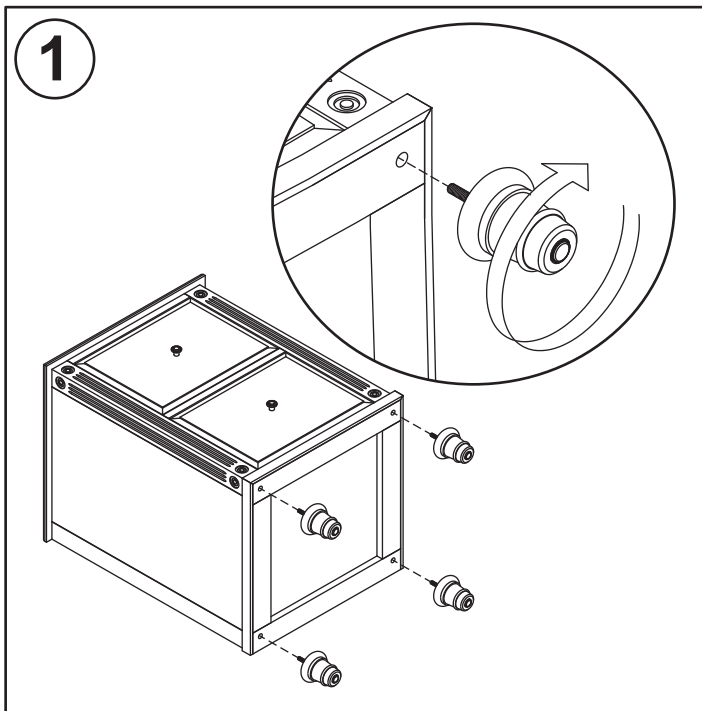

NOTE
Set furniture into place and level before anchoring to wall.

PRODUCTS ARE NOT INTENDED FOR COMMERCIAL USE.
UPDATED: 4-19-2023





Cleaning and Care

Periodically dust with a soft, dry cloth.
Prevent finish damage: do not use alcohol based cleaners or polishers. Promptly remove spills.

MADE IN VIETNAM

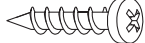
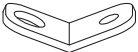
WALL ANCHORING HARDWARE (ANTI-TIP)

Ltr.	Qty.	Hardware Included
A	2	 Large Screw
B	2	 Small Screw
C	4	 Bracket
D	2	 Retention Belt



Installation:

1. Place furniture against wall at desired location then locate and mark a Wall Stud behind unit.
2. Corresponding to Stud location, attach one Bracket (C) to back of unit using Small Screw (B).
3. To keep hardware out of view after installation, attach remaining Bracket (C) **INTO WALL STUD** with Large Screw (A) 2 inches below Bracket attached to back of unit.
4. Move unit into place, align Brackets then connect both using Retention Belt (D).
5. Confirm Belt is securely laced and locked.

