

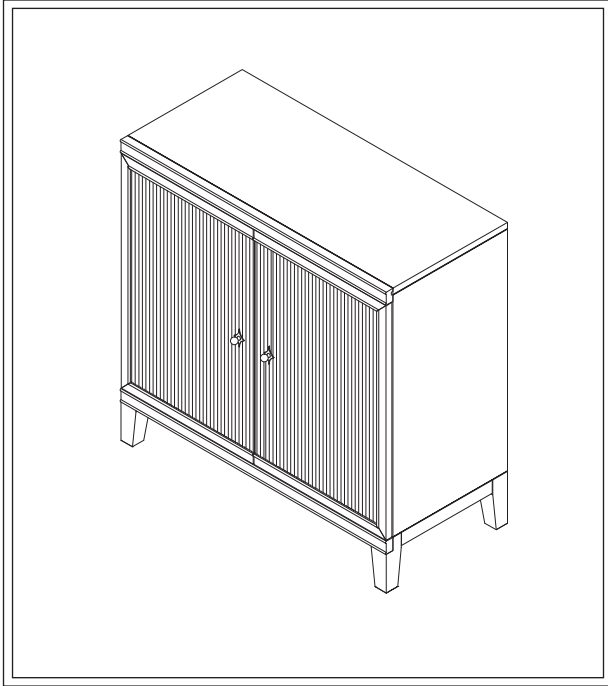









PRODUCT NAME: Amelia Cabinet  
ITEM NUMBER: MS150  
ASSEMBLED DIMENSIONS : 34 1/4"H x 35"W x 16 1/8"D

**REQUIRED TOOLS:**  
Phillips Screwdriver

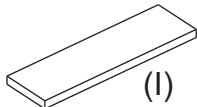

Ltr.	Qty.	Hardware/Components Included	
A	4		Shelf Supports
B	2		*Allen Bolts M8 x 40mm
C	2		*Flat Washers M8 x 20mm
D	2		*Lock Washers M8 x 14mm
E	1		*Connector Plate
F	1		*Allen Wrench (5mm)
G	2		Wall Anchoring (Anti-tip) Kits (Page 2 )
H / I	1 / 1	 (H)	 (I) Cabinet / Shelf

\*Used with joining multiple cabinets. (OPTIONAL/See Page 2)

**SHELF:** Insert Shelf Supports (A) into pre-drilled holes. Set Shelf (I) level upon Supports.  
**LEVELERS:** Set Cabinet into location and adjust pre-installed Levelers as necessary. See inset below.  
If joining multiple Cabinets, level each BEFORE joining using Connector Plates.

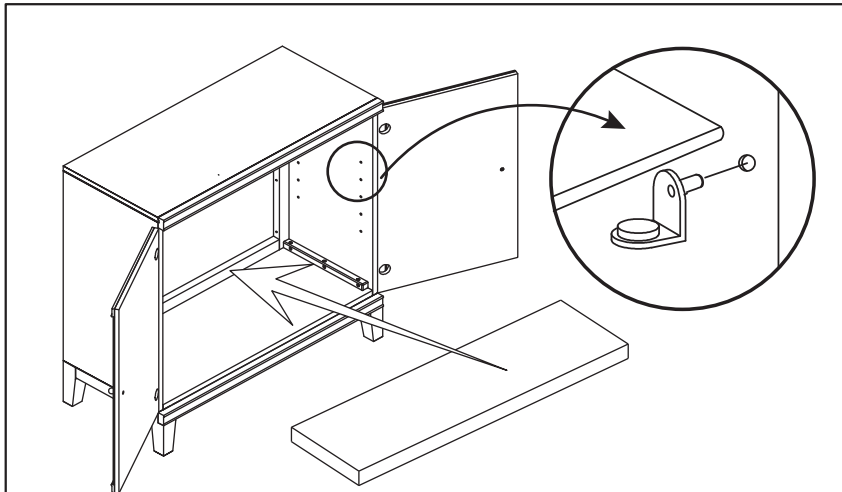

### Cleaning and Care

Periodically dust with a soft, dry cloth.  
Protect surfaces to prevent damage.  
Do not use alcohol based cleaners or polishers.

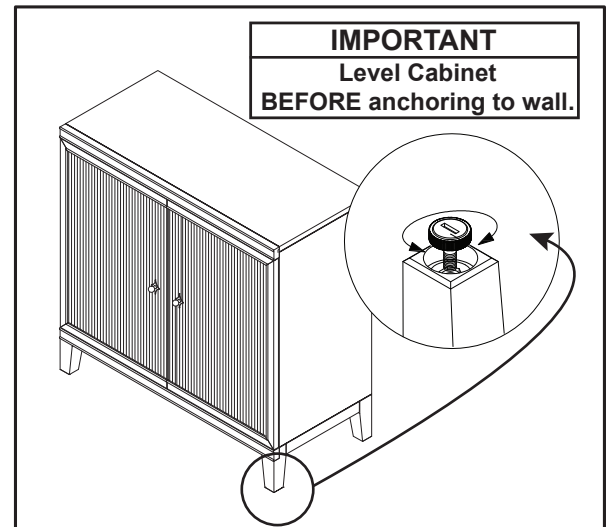

**LEVELERS:** Cabinet is equipped with Rotary Levelers installed under each corner. If necessary, adjustments may be made by carefully lifting applicable corner and turning Leveler clockwise/counterclockwise.

PRODUCTS ARE NOT INTENDED  
FOR COMMERCIAL USE.  
UPDATED: 11-17-2022

MADE IN INDONESIA



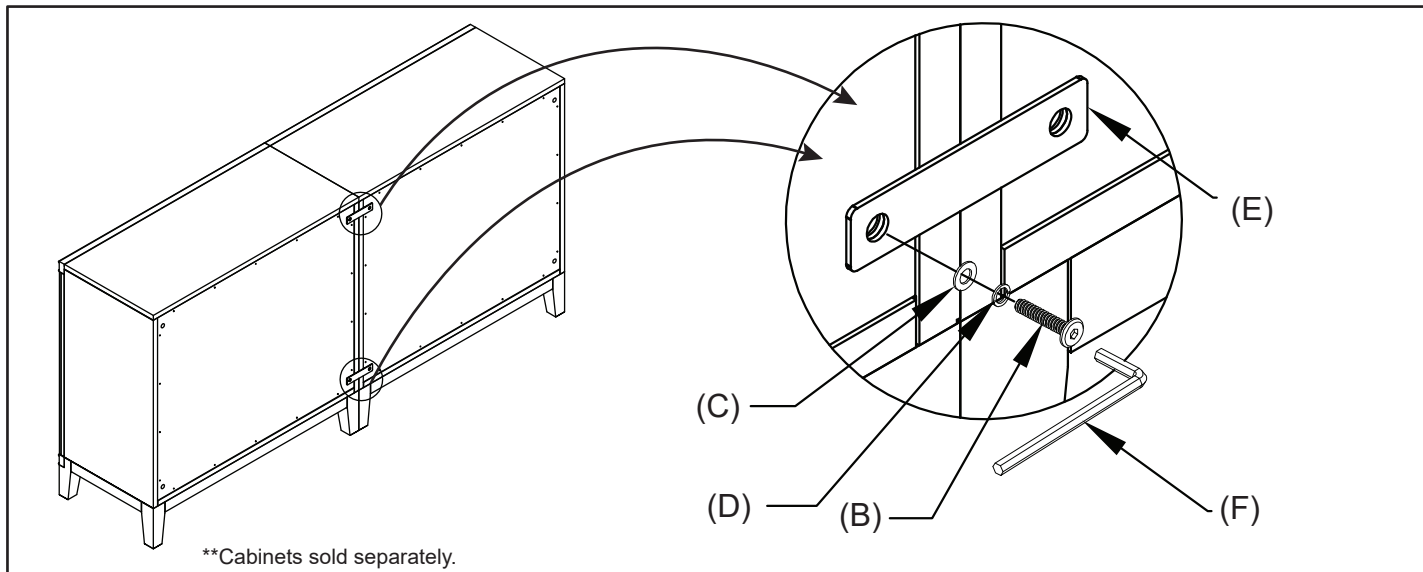

**⚠ Assemble in location for intended use.**

**OPTIONAL:** Multiple Amelia Cabinets\*\* may be joined . First, move each Cabinet into location for use, adjust levelers as needed then join using Connector Plate(s) (E) secured with Allen Bolts (B), Lock Washers (D) and Flat Washers (C). Fully tighten using Allen Wrench (F).

**IMPORTANT:** Level Cabinets individually and as a group **BEFORE** joining and/or anchoring to wall.

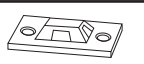

### WALL ANCHORING HARDWARE (ANTI-TIP)

Ltr.	Qty.	Hardware Included
A	4	 Small Screw
B	4	 Large Screw
C	4	 Bracket
D	2	 Retention Belt

#### ANCHORING HARDWARE INSTALLATION

1. Locate and mark a **WALL STUD** behind Cabinet(s).
2. Corresponding to **STUD LOCATION**, attach a Bracket (C) to back of Cabinet using Small Screw (B).
3. To keep hardware out of view after installation, attach remaining Bracket **INTO WALL STUD** using Large Screw (A) two inches below Bracket on Cabinet.
4. Move Cabinet into place, align Brackets then join with Retention Belt (D).
5. Confirm Belt is securely laced and locked.

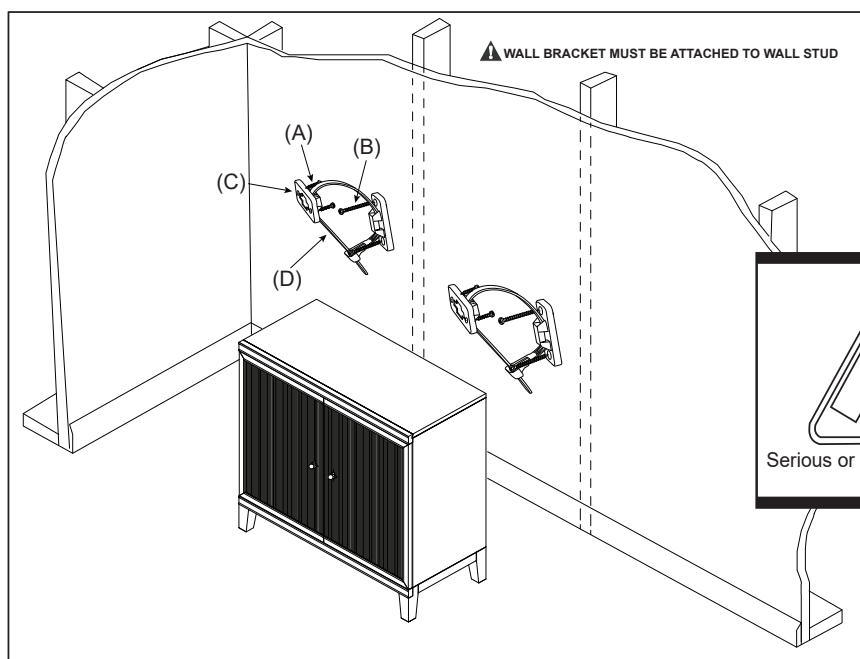



**WARNING**  
Tip-Over Hazard

Serious or fatal crushing injuries can occur from a furniture tip-over  
Prevent tipping accidents. Anchor your furniture.



Customer Service: 800-367-2810  
Online: [www.ballarddesigns.com](http://www.ballarddesigns.com)