

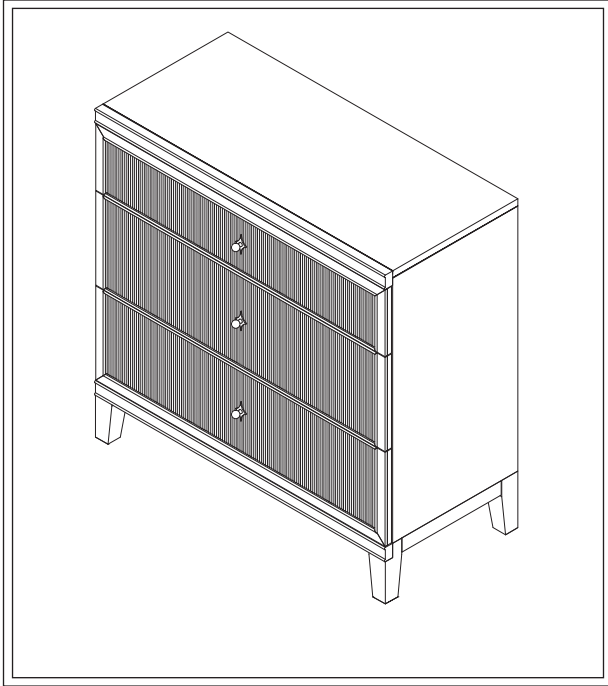







PRODUCT NAME: Amelia Chest of Drawers
ITEM NUMBER: MS151
ASSEMBLED DIMENSIONS : 34 1/4"H x 35"W x 16 1/8"D

REQUIRED TOOLS:

*Phillips Screwdriver

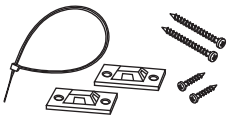

Ltr.	Qty.	Hardware/Components Included
A	2	 *Allen Bolts M8 x 40mm
B	2	 *Flat Washers M8 x 20mm
C	2	 *Lock Washers M8 x 14mm
D	1	 *Allen Wrench (5mm)
E	1	 *Connector Plate
F	2	 Wall Anchoring (Anti-tip) Kits (Page 2)

*Used when joining multiple Amelia units. (OPTIONAL/See Page 2)

LEVELERS: Set Chest of Drawers into place and adjust Levelers as necessary.

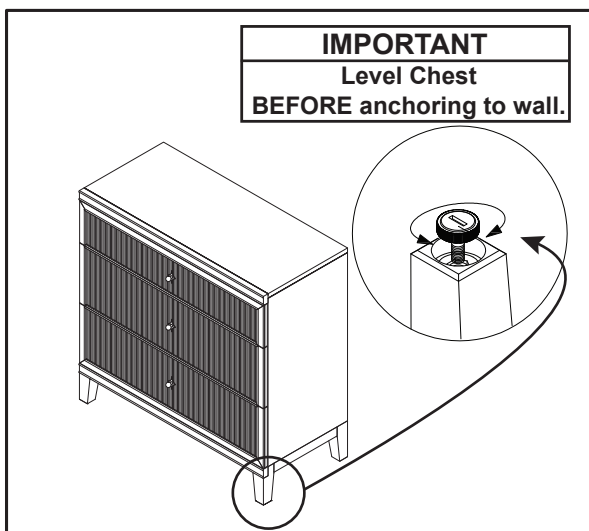

LEVELERS: Cabinet is equipped with Rotary Levelers installed under each corner. If necessary, adjustments may be made by carefully lifting applicable corner and turning Leveler clockwise/counterclockwise.



Cleaning and Care

Periodically dust with a soft, dry cloth.
Protect surfaces to prevent damage.
Do not use alcohol based cleaners or polishes.



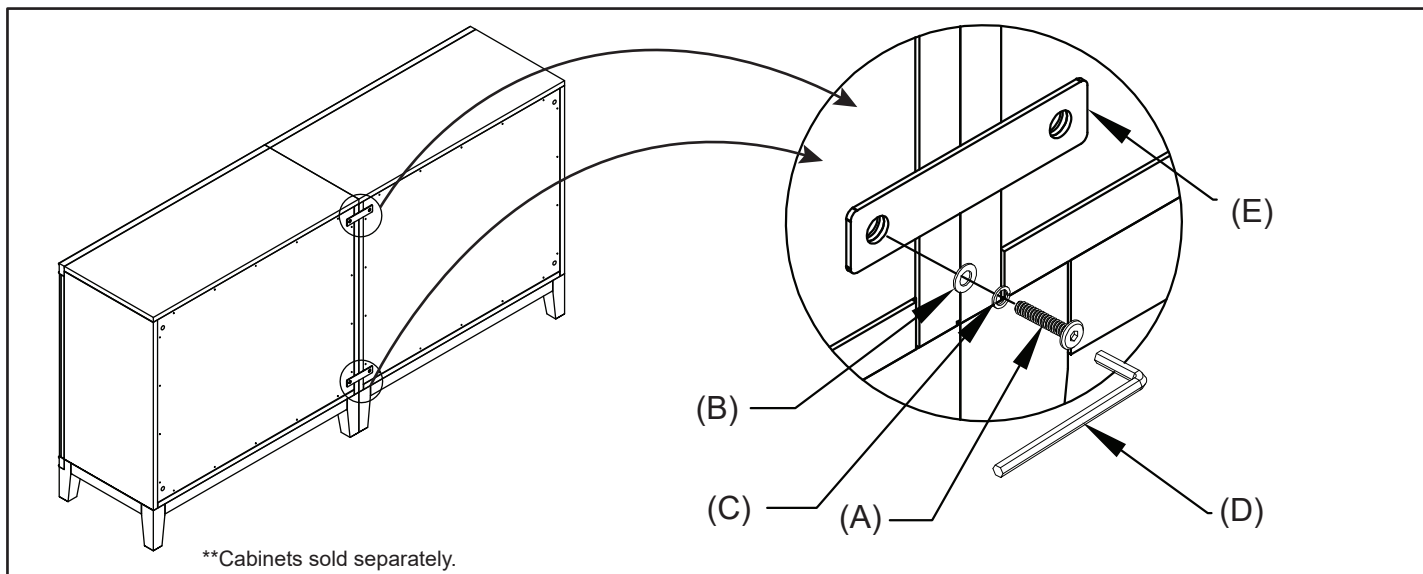

⚠ Assemble in location for intended use.

OPTIONAL: Multiple Amelia units** may be joined . First, move each unit into location for use, adjust levelers as needed then join using Connector Plate(s) (E) secured with Allen Bolts (A), Lock Washers (C) and Flat Washers (B). Fully tighten using Allen Wrench (D).

IMPORTANT: Level units individually and as a group **BEFORE** joining and/or anchoring to wall.

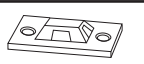

WALL ANCHORING HARDWARE (ANTI-TIP)

Ltr.	Qty.	Hardware Included
A	4	 Small Screw
B	4	 Large Screw
C	4	 Bracket
D	2	 Retention Belt

ANCHORING HARDWARE INSTALLATION

1. Locate and mark a **WALL STUD** behind Cabinet(s).
2. Corresponding to **STUD LOCATION**, attach a Bracket (C) to back of Cabinet using Small Screw (B).
3. To keep hardware out of view after installation, attach remaining Bracket **INTO WALL STUD** using Large Screw (A) two inches below Bracket on Cabinet.
4. Move Cabinet into place, align Brackets then join with Retention Belt (D).
5. Confirm Belt is securely laced and locked.

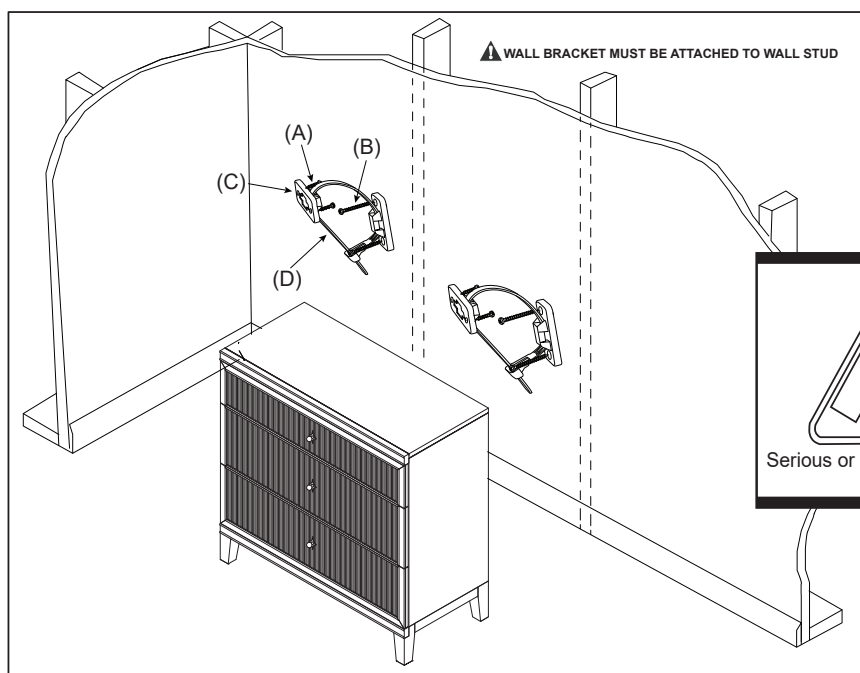



WARNING
Tip-Over Hazard

Serious or fatal crushing injuries can occur from a furniture tip-over
Prevent tipping accidents. Anchor your furniture.



Customer Service: 800-367-2810
Online: www.ballarddesigns.com