





PRODUCT NAME: Andrews Console Table
ITEM NUMBER: SL033
ASSEMBLED DIMENSIONS: 34 1/4"H x 72 1/4"W x 15"D

REQUIRED TOOLS:

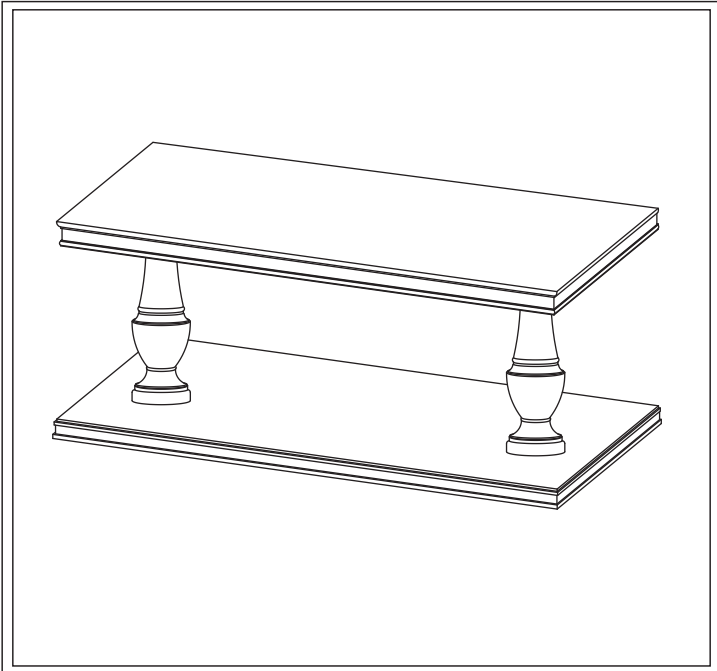

Wrench (included)
- Two person assembly suggested.

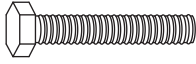
ASSEMBLY TIME: 15 - 20 minutes

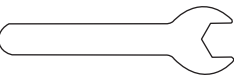

Ltr.	Qty.	Hardware Included	
A	*16		*Hex Bolts (M8 x 40mm)
B	*16		*Lock Washers (M8)
C	*16		*Flat Washers (M8 x 19 x 2mm)
D	1		Wrench (12mm)

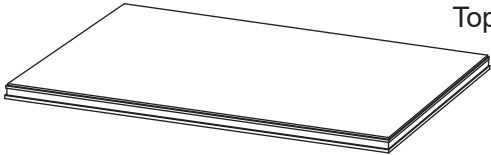
***8 PIECES PRE-INSTALLED See Page 2, STEP 1.**

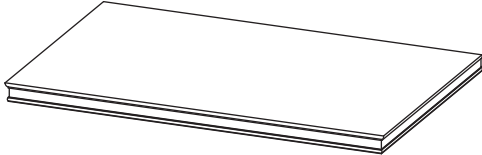
Ltr.	Qty.	Components	
E	1		Top (E)
F	2		Legs (F)
G	1		Base (G)



Cleaning and Care

Periodically dust with a soft, dry cloth.
Protect surfaces to prevent damage.
Do not use alcohol based cleaners or polishers.

STEP 1: Invert Top (E) onto a level, padded surface. Remove both pre-attached BRIDGES by removing Bolts, Lock and Flat Washers using Wrench (D).
IMPORTANT: RETAIN BOLTS AND WASHERS TO COMPLETE STEP 3.

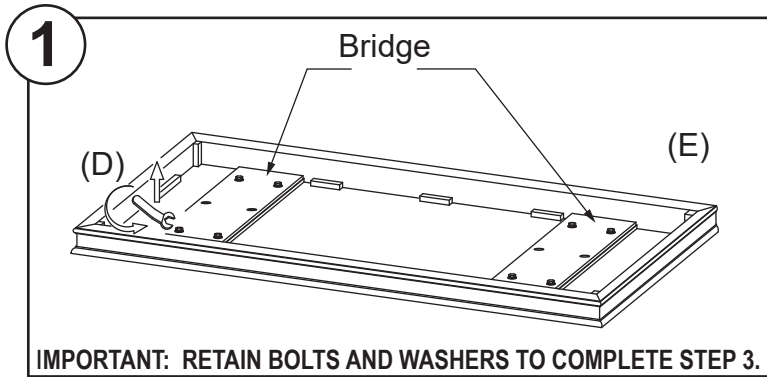

STEP 3: Carefully invert and place Legs (F) onto Top. Align holes then secure using Hex Bolt (A), Lock Washer (B) and Flat Washer (C). Tighten using Wrench (D).

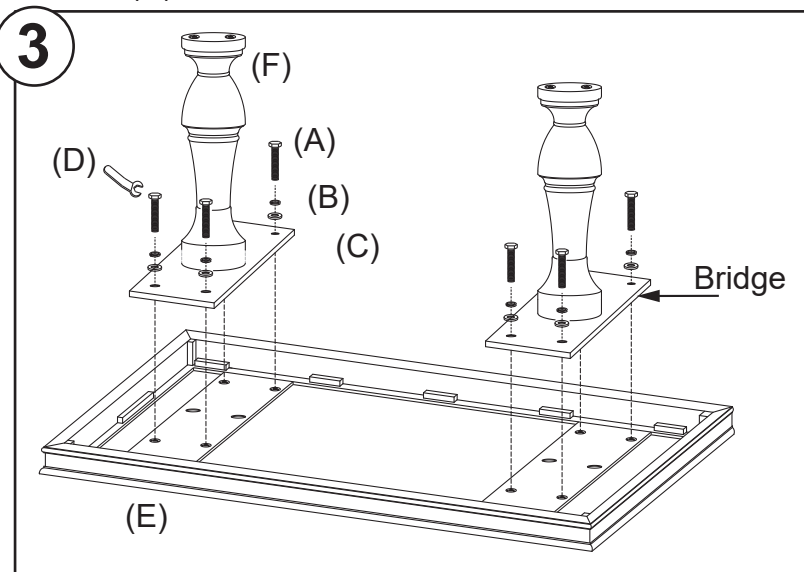

Console is equipped with **ROTARY LEVELERS** installed under each corner. Adjustments may be made by lifting applicable corner and turning Leveler clockwise/counterclockwise.

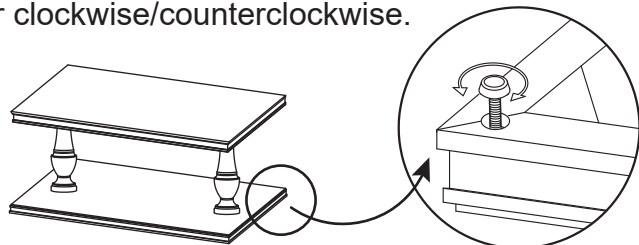

STEP 2: Align center holes in Bridge with those in Leg (F). Secure using Hex Bolt (A), Lock Washer (B) and Flat Washer (C). Tighten using Wrench (D).

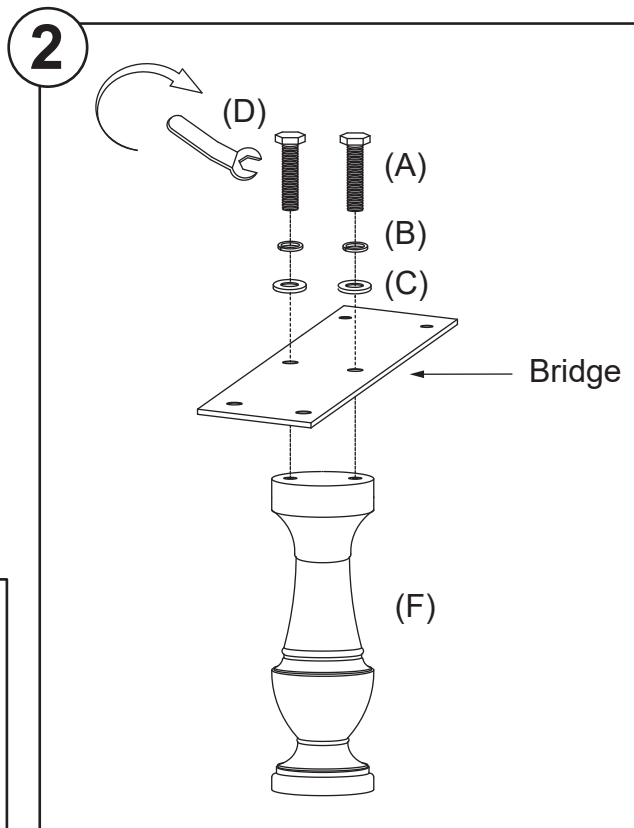

STEP 4: Set Base (G) onto Legs (F). Align holes then secure using Hex Bolts (A), Lock Washers (B) and Flat Washers (C). Tighten using Allen Wrench (D). Turn Console Table upright.

