

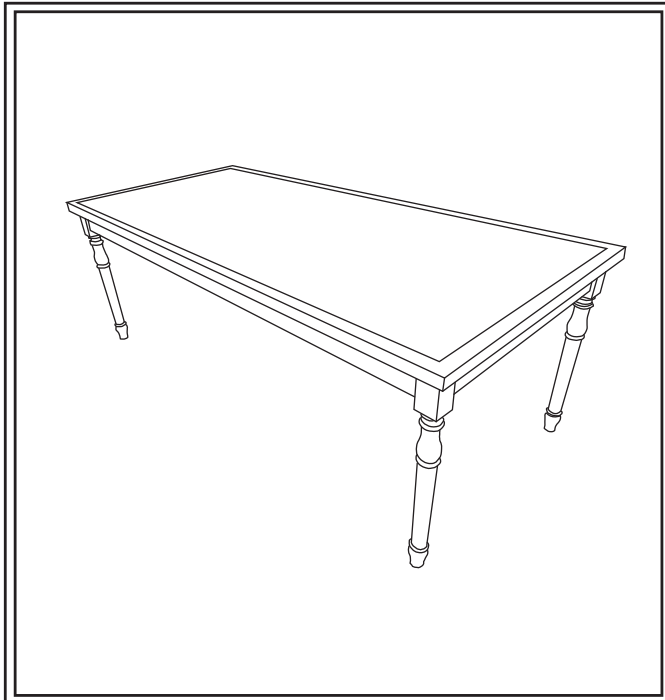

PRODUCT NAME: Calais Dining Table
ITEM NUMBER: SL185
ASSEMBLED DIMENSIONS : 29"H x 39"W x 86"L







Prevent accidentally discarding small parts or hardware. Retain all carton contents until assembly and installation are complete.



REQUIRED TOOLS:

Socket Tool (included)
Screwdriver (for leverage)
-Two person assembly suggested.

Remove all parts, hardware and protective packaging from carton and carefully arrange on a clean, level, padded surface.

Ltr.	Qty.	Hardware Included	
A	4		Levelers
B	8		Hex Nuts
C	8		Flat Washers
D	1		Socket Tool

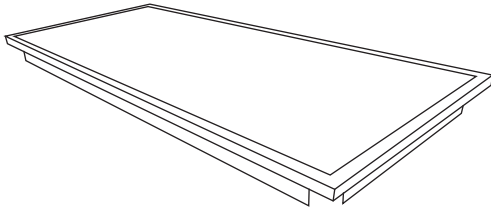
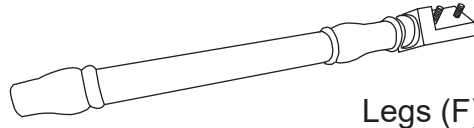
Ltr.	Qty.	Components
E	1	 Top (E)
F	4	 Legs (F)



Cleaning and Care

Avoid harsh or abrasive chemicals as finish damage may result.
Use coasters, trivets, placemats to protect surfaces.
Promptly remove spills. Dust with a soft, dry cloth.

⚠ Assemble in location for intended use.

STEP 1: Invert Top (E) onto a level padded surface then carefully fit each Leg (F) into a corner by aligning and placing threaded studs through holes in metal corner brackets. Secure using a Flat Washer (C) with Hex Nut (B). Tighten each with enclosed Socket Tool (D). **NOTE:** Use a screwdriver for leverage. (Fig. 1)

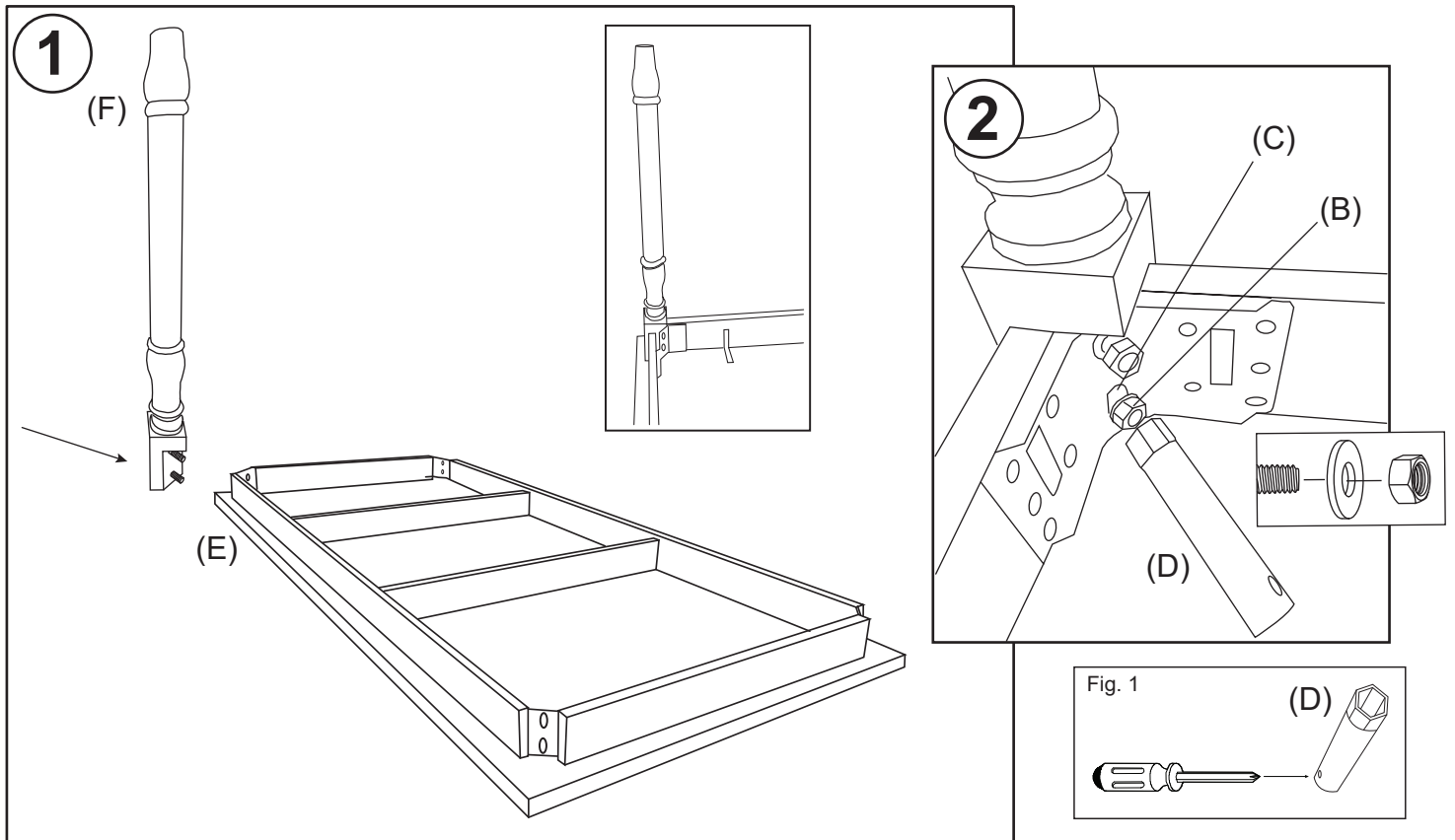

STEP 2: Before turning assembled table upright, insert and loosely tighten a Leveler (A) into base of each Leg (F). Turn table upright and place in location for use. If necessary, table may be adjusted by lifting applicable Leg and turning Leveler clockwise/counterclockwise.

