

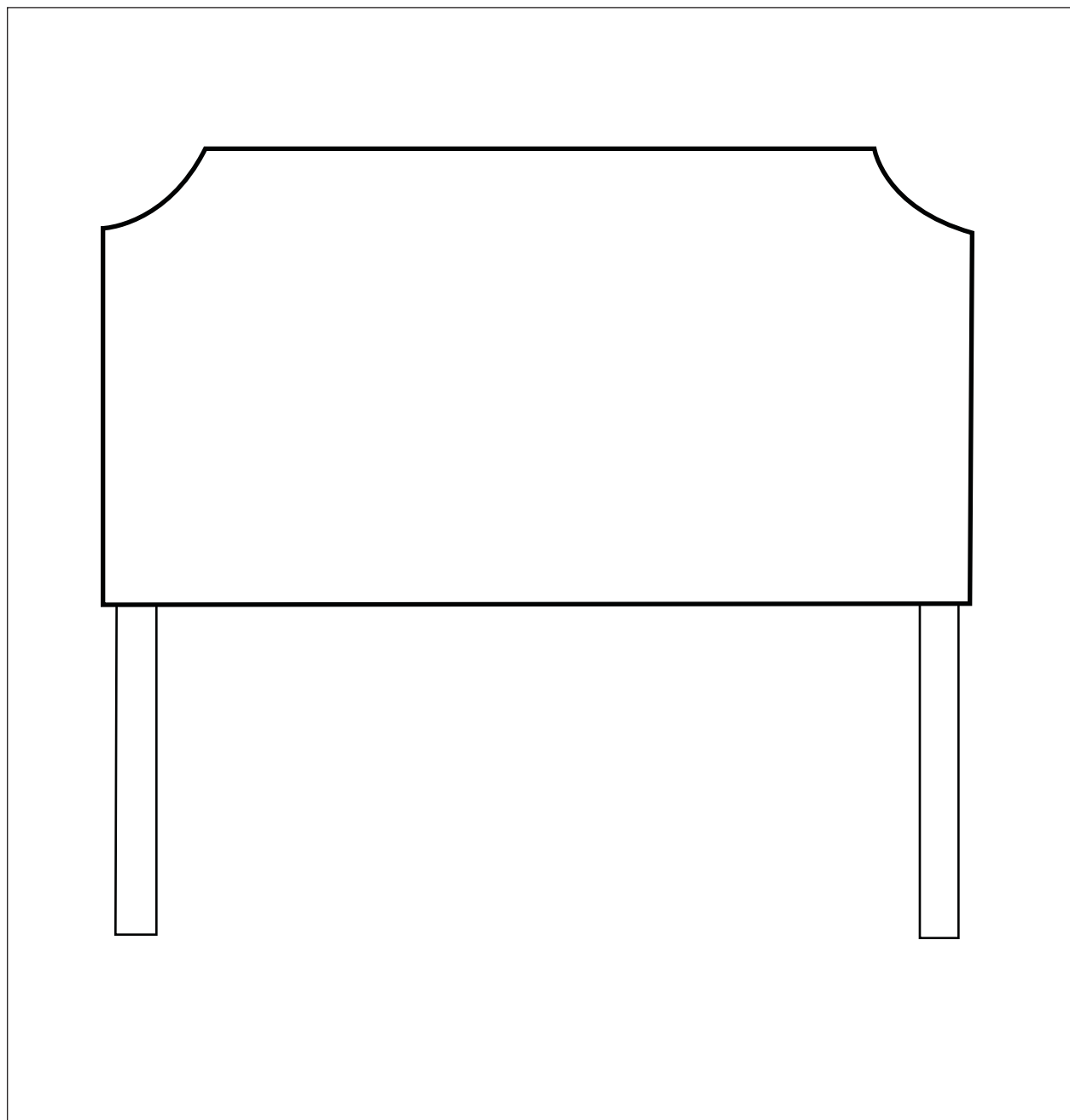

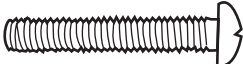

PRODUCT NAME: Stevenson Headboard

ITEM NUMBER: SH003, SH005

DIMENSIONS OF MATTRESS SIZE: Twin, Full, Queen, & King



Ltr.	Qty.	Hardware Included
A	4	 2" Screw
B	4	 1/2" Lock Washer
C	4	 Wood Screw
D	4	 Raised Washer

TOOLS NEEDED:
Phillips screwdriver

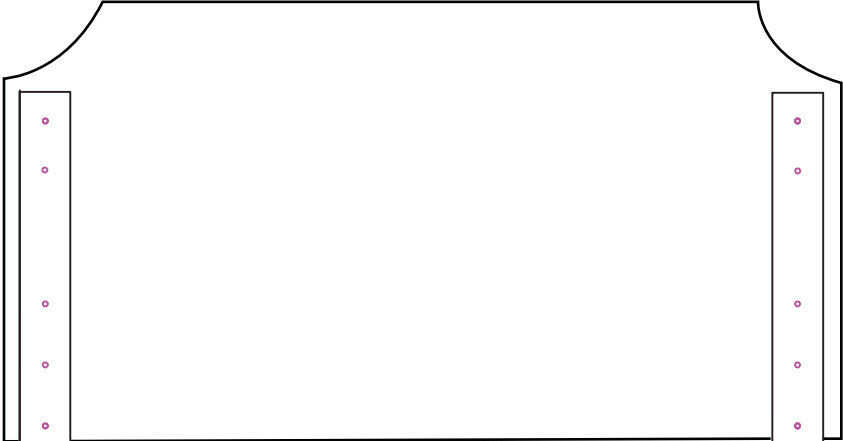
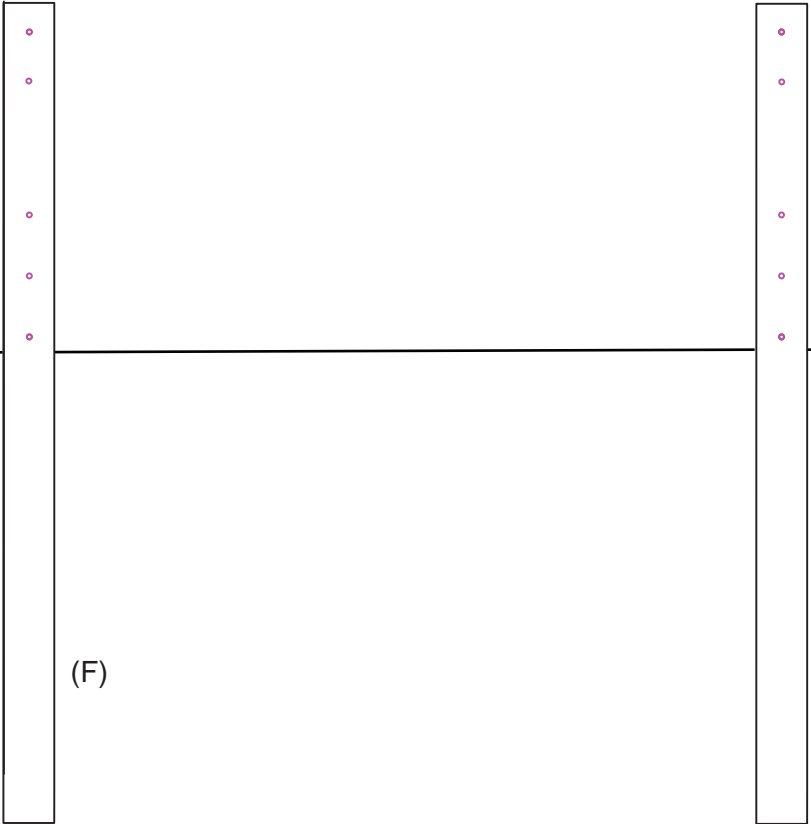
Ltr.	Qty.	Components
E	1	<p>(E)</p> 
F	2	<p>(F)</p> 

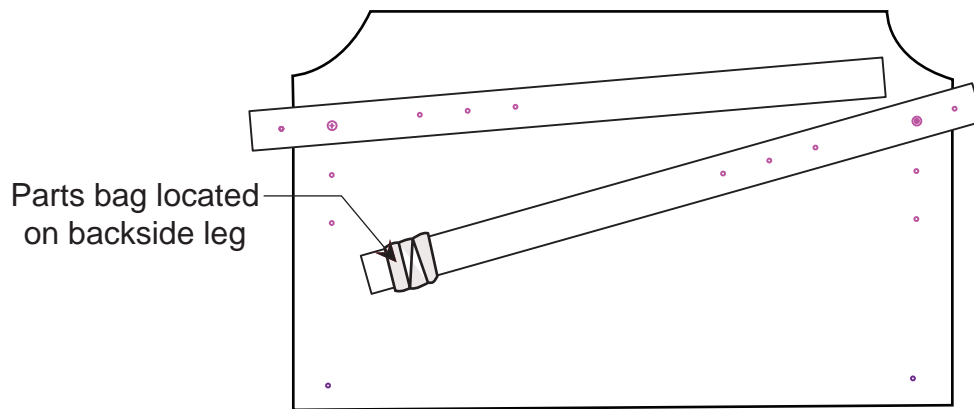

STEP 1: Place headboard face down on a clean surface. The 2nd screw has been installed at the factory. Straighten both legs so the predrilled holes line up with each other. The legs can be adjusted to 4 different heights to accommodate your mattress height. Feel for the holes (under the fabric) along the middle of the leg. Once you feel the holes and have figured out the height of your headboard, take a pair of scissors & cut a small hole over the necessary holes.

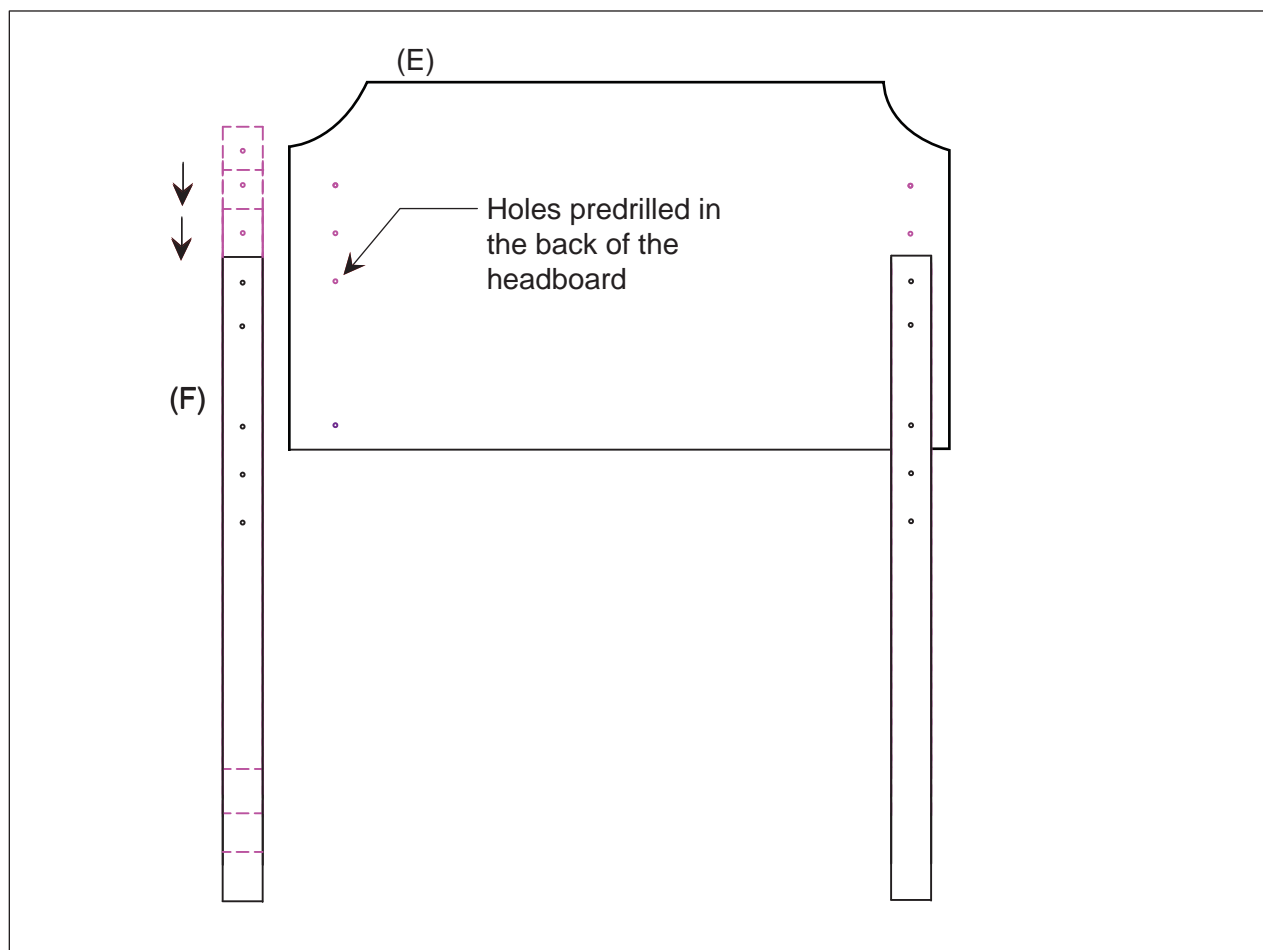

STEP 2: For each leg use one screw & washer in the top hole or 2nd hole, and the other screw and washer on the lower coordinating hole with a screwdriver.

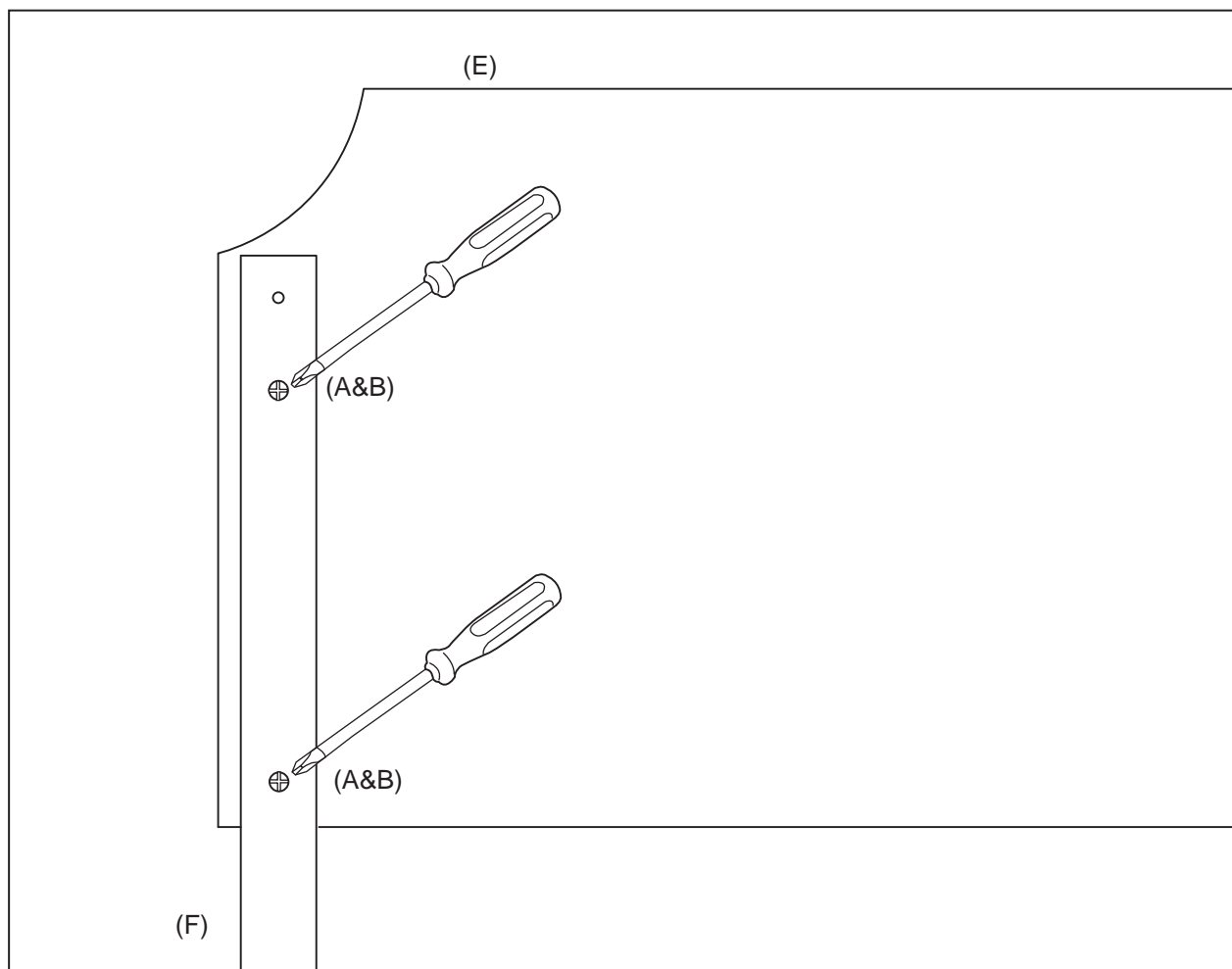

STEP 3: Attach the headboard to the bedframe. Place washer (D) on one of the screws (C) and insert it through the slots in your bedframe. Use the screwdriver to securely tighten the screw to the leg of the headboard. You will need to drill a pilot hole.

