

PRODUCT NAME: Squire Bed King/Queen

ITEM NUMBER: UM016; UM017

DIMENSIONS OF ITEM ASSEMBLED: King- 57"H x 82"W x 91 3/4"D

Queen- 57"H x 63 1/4"W x 91 3/4"D

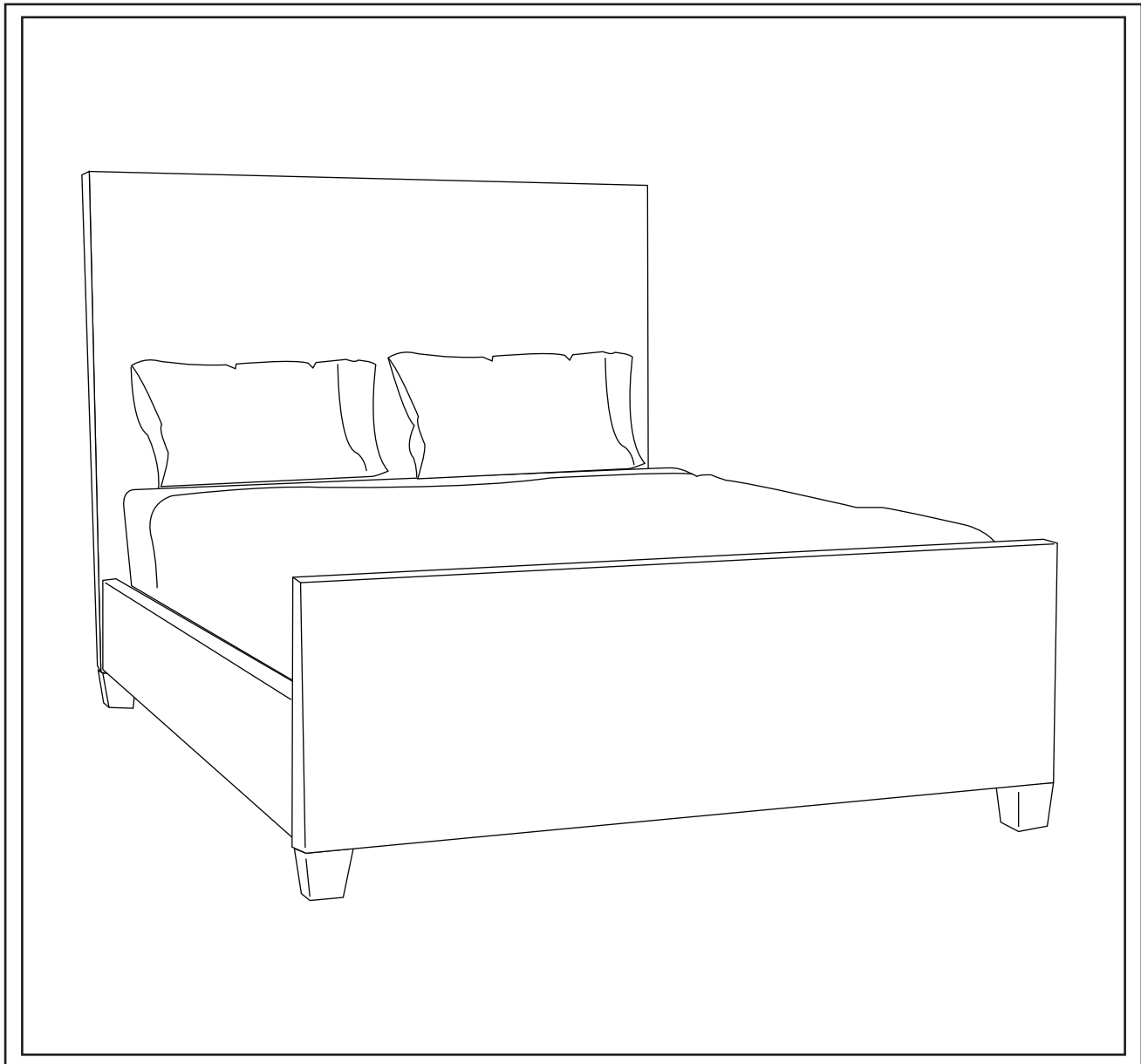

⚠ Assemble in location for intended use.



Prevent accidentally discarding small parts or hardware. Retain all carton contents until assembly and installation are complete.

**NO TOOLS REQUIRED
TWO OR MORE PEOPLE SUGGESTED FOR ASSEMBLY**

Ltr.	Qty.	Components
A	4	Legs w/Rotary Levelers (A)
B	4	Supports (B)
C	1	Headboard (C)
D	2	Sideboards (D)
E	1	Footboard (E)

▲ Assemble in location for intended use.

STEP 1: Attach Sideboards (D) to Headboard (C) and Footboard (E) by aligning Hooks and Slots, inserting and pushing down to lock in place. Hook one side at a time, then check that each is fully seated, locked and secured.

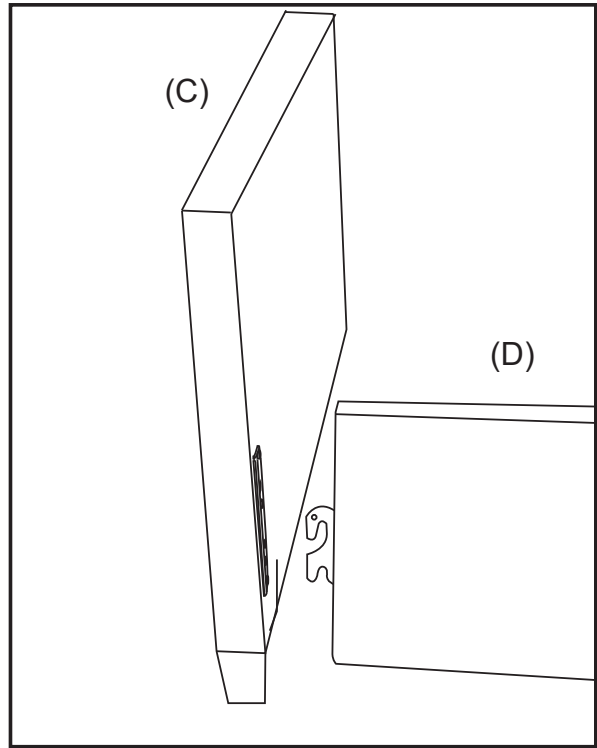
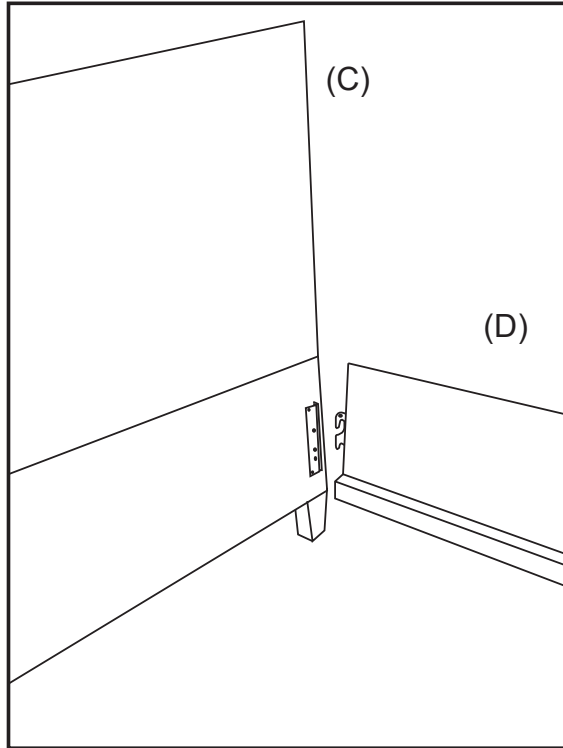

STEP 2: Turn each Leg (A) into T-nut embedded in center of each Support (B). NOTE: For optimal support, flip Supports so T-nuts are facing up.

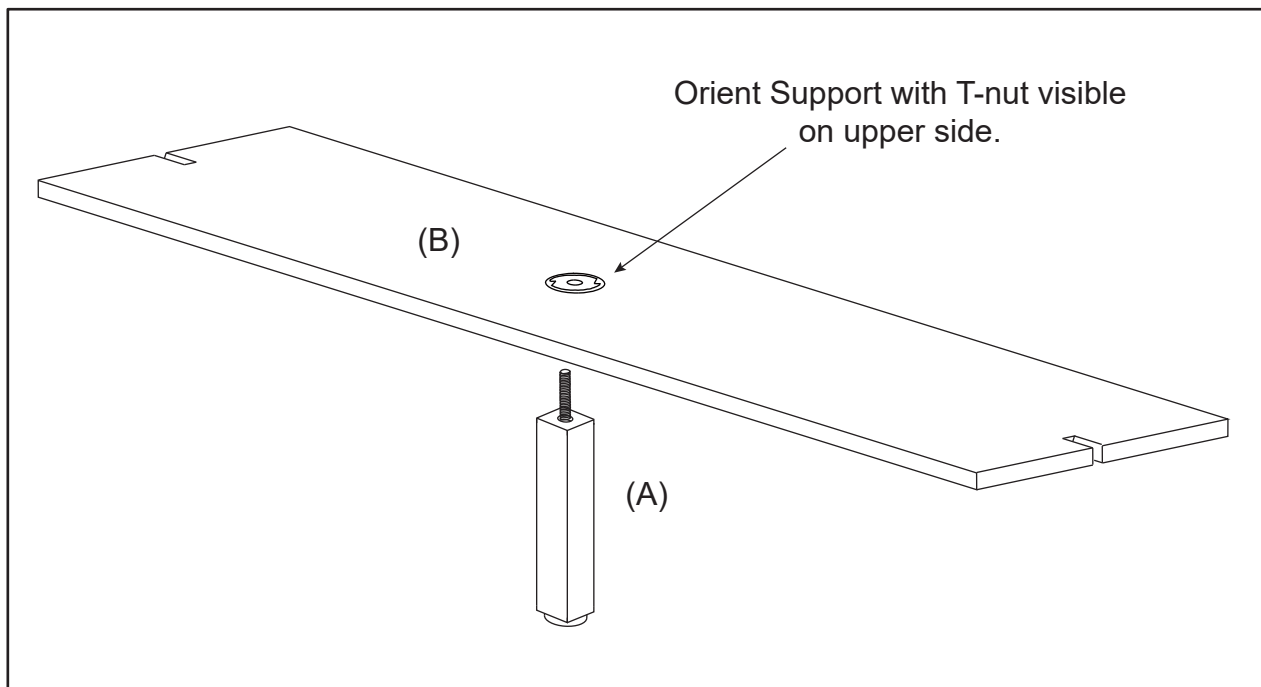

 Assemble in location for intended use.

STEP 3: Align notches in ends of Supports (B) with Pegs on Sideboards (D) then carefully lay each Support into place.



Each Leg is equipped with a Rotary Leveler. Supports should not bow or bounce. Turn Leveler clockwise/counterclockwise until Leg completely touches floor and each Support is level.

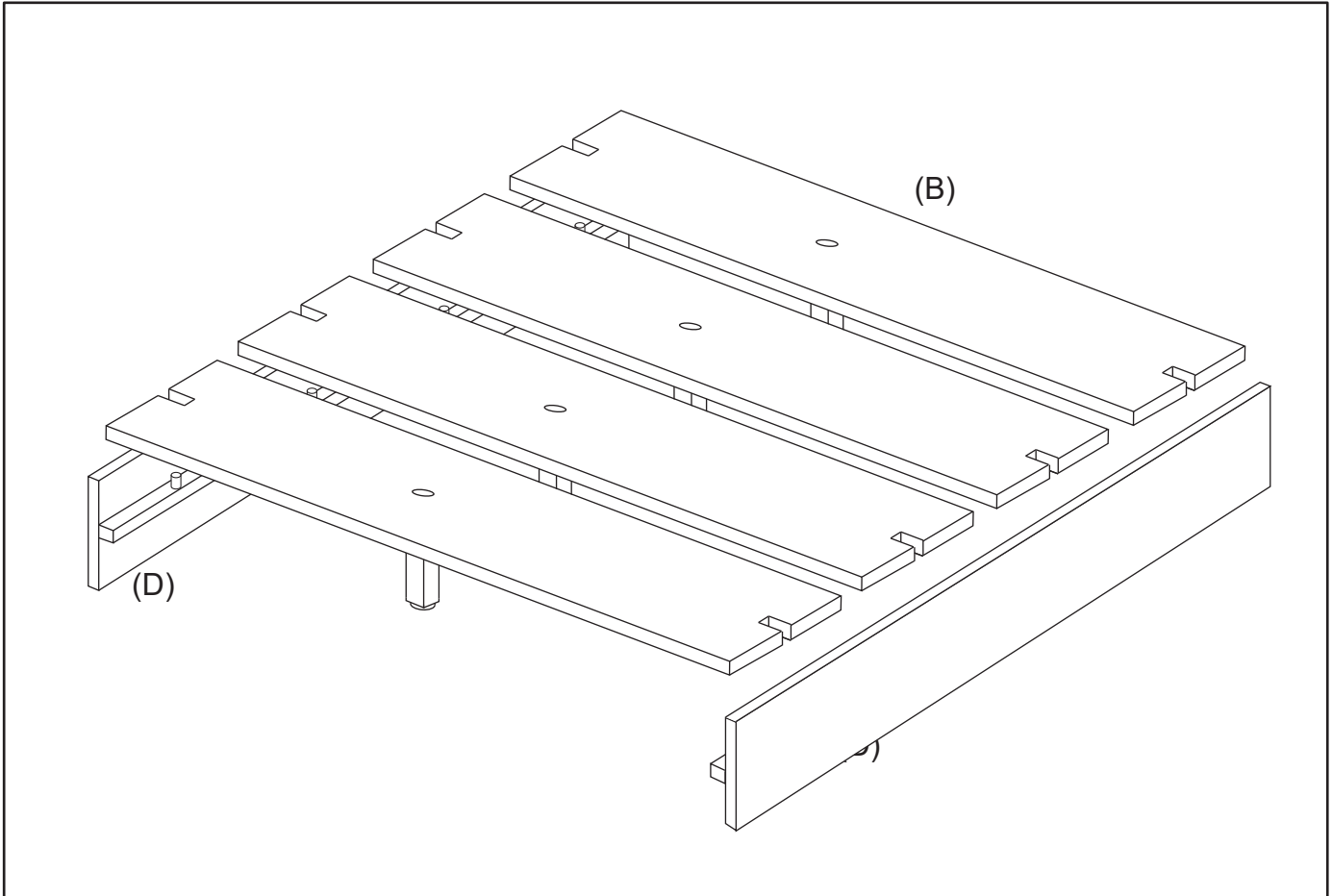

Cleaning and Care

Spot clean as needed.
Specific cleaning method varies by fabric type.